

AKAI SERVICE MANUAL

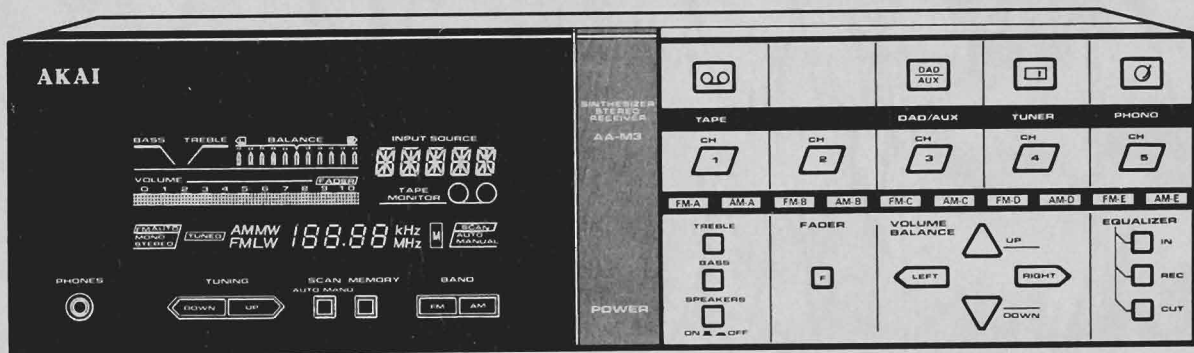

MC-Service

SYNTHESIZER STEREO RECEIVER

MODEL **AA-M3**

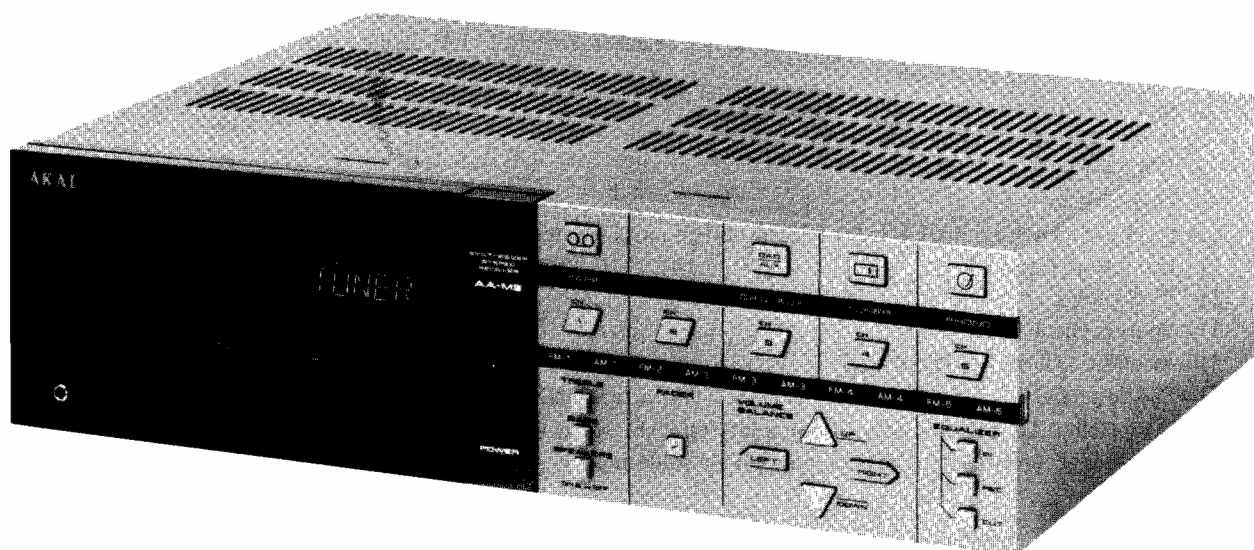

SYNTHESIZER STEREO RECEIVER

MODEL AA-M3

SECTION 1	SERVICE MANUAL	3
SECTION 2	PARTS LIST	25
SECTION 3	SCHEMATIC DIAGRAM	34

SAFETY INSTRUCTIONS

SAFETY CHECK AFTER SERVICING

Confirm the specified insulation resistance between power cord plug prongs and externally exposed parts of the set is greater than 10 Mohms, but for equipment with external antenna terminals (tuner, receiver, etc.) and is intended for **C** or **A**, specified insulation resistance should be more than 2.2 Mohms (ground terminals, microphone jacks, headphone jacks, line-in-out jacks etc.)

PRECAUTIONS DURING SERVICING

1. Parts identified by the \triangle symbol parts are critical for safety.
Replace only with parts number specified.
2. In addition to safety, other parts and assemblies are specified for conformance with such regulations as those applying to spurious radiation. These must also be replaced only with specified replacements.
Examples: RF converters, tuner units, antenna selector switches, RF cables, noise blocking capacitors, noise blocking filters, etc.
3. Use specified internal wiring. Note especially:
 - 1) Wires covered with PVC tubing
 - 2) Double insulated wires
 - 3) High voltage leads
4. Use specified insulating materials for hazardous live parts. Note especially:
 - 1) Insulation Tape
 - 2) PVC tubing
 - 3) Spacers (Insulating Barriers)
 - 4) Insulation sheets for transistors
 - 5) Plastic screws for fixing microswitch (especially in turntable)
5. When replacing AC primary side components (transformers, power cords, noise blocking capacitors, etc.), wrap ends of wires securely about the terminals before soldering.

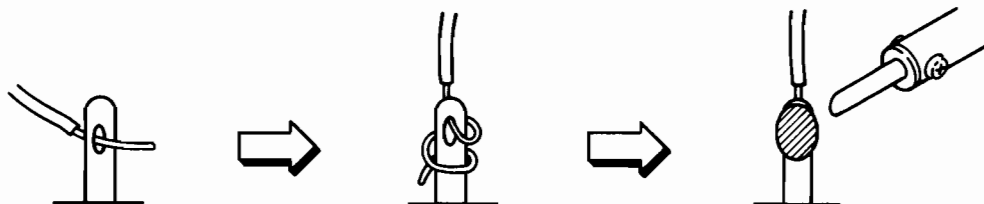

6. Observe that wires do not contact heat producing parts (heatsinks, oxide metal film resistors, fusible resistors, etc.).
7. Check that replaced wires do not contact sharp edged or pointed parts.
8. Also check areas surrounding repaired locations.
9. Use care that foreign objects (screws, solder droplets, etc.) do not remain inside the set.
10. Voltage Conversion
Models for Japan, Canada, USA, Europe, UK and Australia are not equipped with this facility. Each machine is preset at the factory according to destination, but some machines can be set to 110V, 120V, 220V or 240V as required. If Voltage Conversion on your machine is possible,
 - 1) Disconnect the power cord.
 - 2) Turn the Voltage Selector located on the rear panel with a screwdriver until the correct voltage is indicated.
(Refer to Fig. 1)

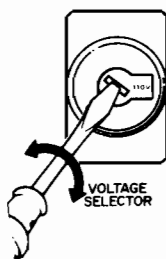

Fig. 1

MC-Service

SECTION 1

SERVICE MANUAL

TABLE OF CONTENTS

I.	SPECIFICATIONS	4
II.	DISMANTLING OF UNIT	5
III.	CONTROLS	6
IV.	PRINCIPAL PARTS LOCATION	7
V.	TUNER ADJUSTMENT	9
	5-1. AM ADJUSTMENT	11
	5-2. FM ADJUSTMENT	12
	5-3. MAIN AMPLIFIER ADJUSTMENT	14
VI.	CLASSIFICATION OF VARIOUS P.C BOARDS	15
	6-1. P.C BOARD TITLES AND IDENTIFICATION NUMBERS	15
	6-2. COMPOSITION OF VARIOUS P.C BOARDS	16

For basic adjustments, measuring methods, and operating principles, refer to GENERAL TECHNICAL MANUAL.

I. SPECIFICATIONS

FM TUNER SECTION

TUNING FREQUENCY RANGE	87.5 MHz to 108 MHz
USABLE SENSITIVITY	16.2 dBf
QUIETING SENSITIVITY (S/N=50 dB) Mono/ST	21.4 dBf/43.7 dBf
CAPTURE RATIO	1.5 dB
SELECTIVITY (400 kHz)	70 dB
IMAGE REJECTION	45 dB
IF REJECTION	90 dB
SPURIOUS REJECTION	90 dB
AM SUPPRESSION	60 dB
SUB CARRIER SUPPRESSION	60 dB
S/N (Mono/ST)	65 dB/60 dB
T.H.D. (Mono/ST)	0.14%
STEREO SEPARATION (1 kHz)	45 dB

AM TUNER SECTION

TUNING FREQUENCY RANGE	520 to 1,610 kHz (USA and Canada) 522 to 1,611 kHz (Others)
USABLE SENSITIVITY (Bar)	300 μ V/m
SELECTIVITY	40 dB
IMAGE REJECTION	50 dB
IF REJECTION	55 dB
S/N RATIO	40 dB
T.H.D.	1%
STATION MEMORY BACK-UP	20 Days
FREQUENCY RANGE	137 kHz to 362 kHz
USABLE SENSITIVITY (IHF)	800 μ V/m
SELECTIVITY (IHF)	35 dB
IMAGE REJECTION	45 dB
IF REJECTION	55 dB
SIGNAL TO NOISE RATIO	35 dB

POWER AMPLIFIER SECTION

RATED POWER OUTPUT (2 channels Driven)	8 ohms 20 to 20,000 Hz: 2 x 25W/0.05%
S/N (IHF-A)	PHONO AUX 73 dB 93 dB
RESIDUAL NOISE (8 ohms)	0.5 mV
CHANNEL SEPARATION (IHF, 1 kHz)	45 dB
DAMPING FACTOR (1 kHz, 8 ohms)	50
AMPLIFIABLE SPEAKER IMPEDANCE	8 to 16 ohms

PRE-AMPLIFIER SECTION

INPUT SENSITIVITY/IMPEDANCE	PHONO TUNER 2.5 mV/47 kohms 150 mV/47 kohms
OUTPUT LEVEL	TAPE REC 150 mV
FREQUENCY RESPONSE	PHONO (RIAA Deviation) TUNER, AUX, TAPE \pm 0.5 dB (20 to 20,000 Hz) 10 Hz to 80 kHz +0, -3 dB
TONE BOOST	BASS TREBLE 5.5 dB (100 Hz) 6.0 dB (10 kHz)
POWER REQUIREMENTS	100V, 50/60 Hz for Japan 120V, 60 Hz for USA & Canada 220V, 50 Hz for Europe except UK 240V, 50 Hz for UK & Australia 110V/120V/220V/240V, 50/60 Hz switchable for other countries
POWER CONSUMPTION	JPN 70W, CSA 100W, AAL 70W, U/T 95W
DIMENSIONS	350(W) x 98(H) x 270(D) mm (13.8 x 3.9 x 10.6 inches)
WEIGHT	5.3 kg (11.7 lbs)

* For improvement purposes, specifications and design are subject to change without notice.

MC-Service

II. DISMANTLING OF UNIT

In case of trouble, etc. necessitating dismantling, please dismantle in the order shown in the photographs. Reassemble in reverse order.

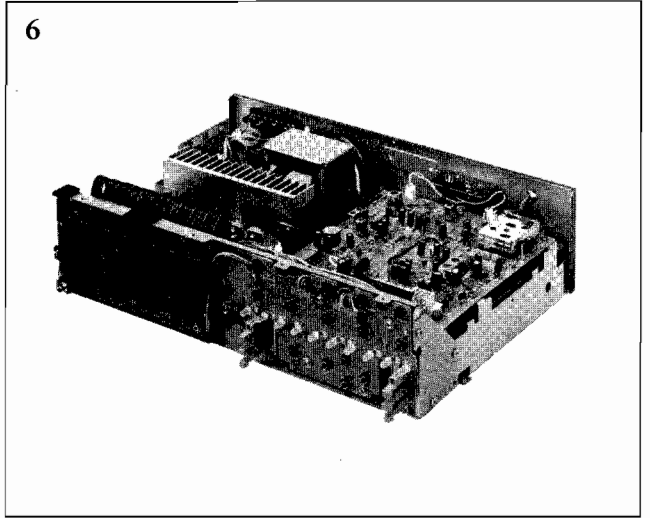
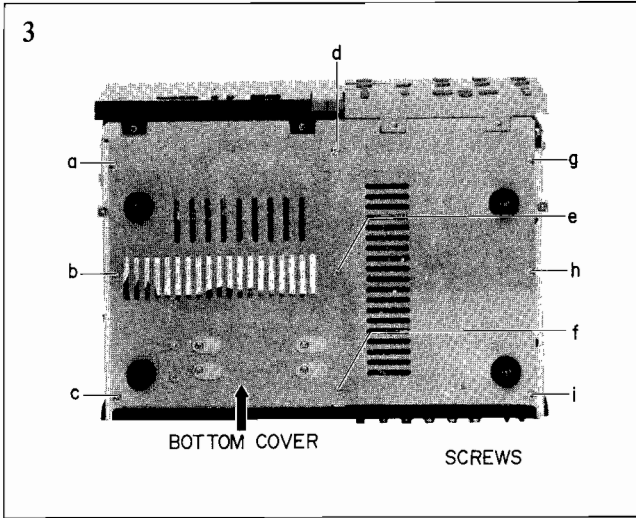
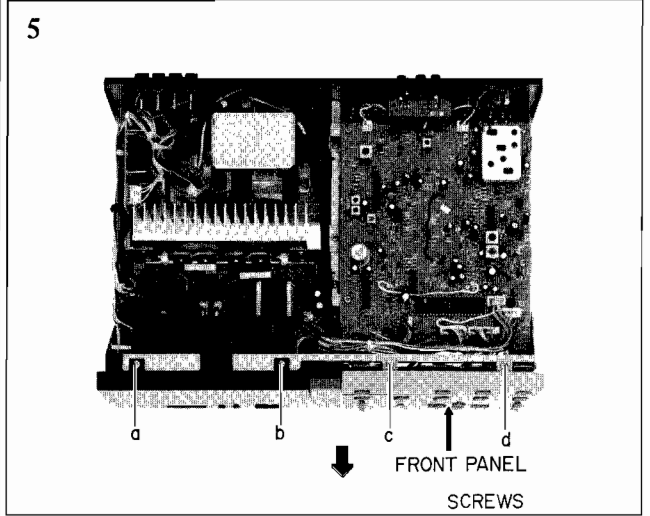
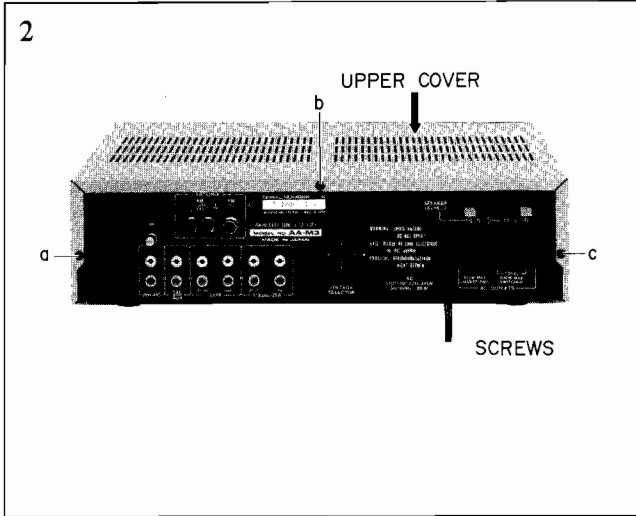
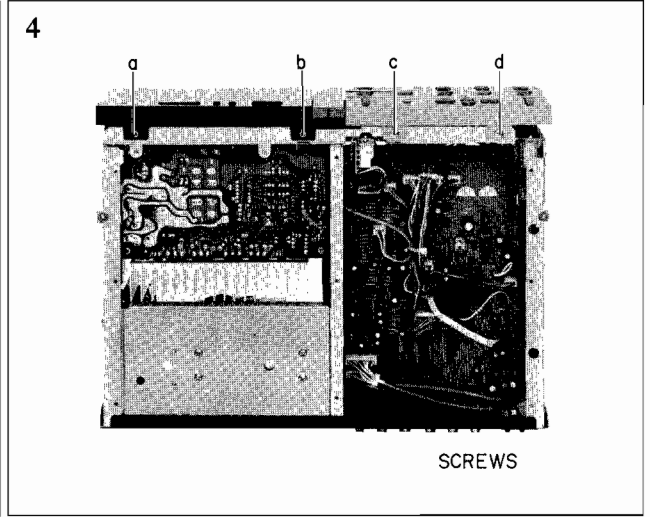
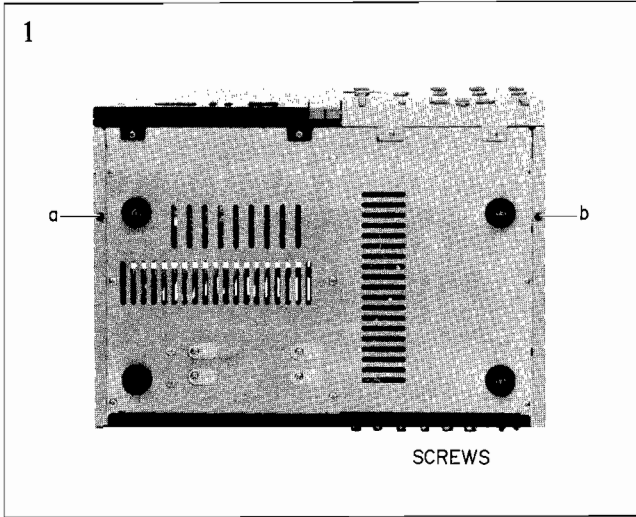

III. CONTROLS

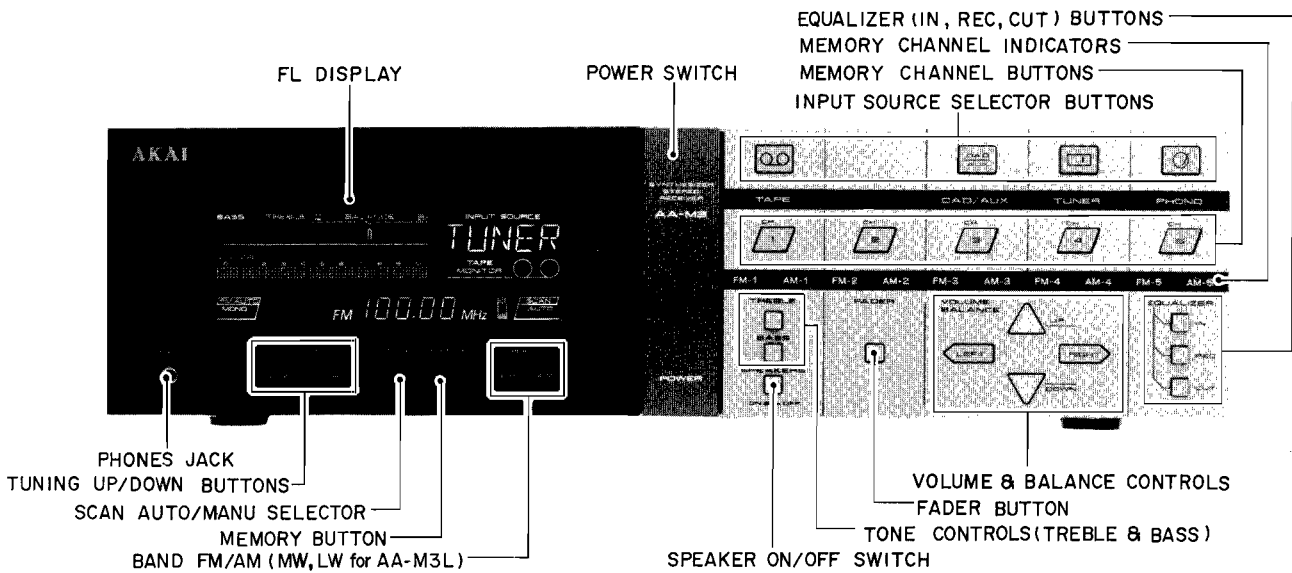

Fig. 3-1

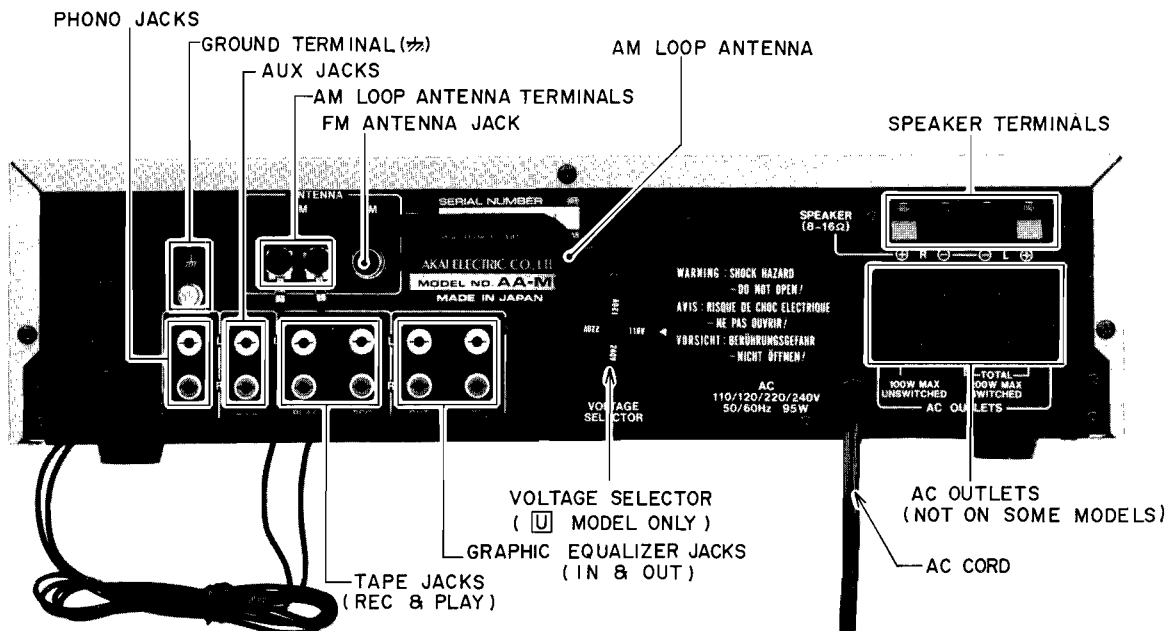

Fig. 3-2

MC-Service

IV. PRINCIPAL PARTS LOCATION

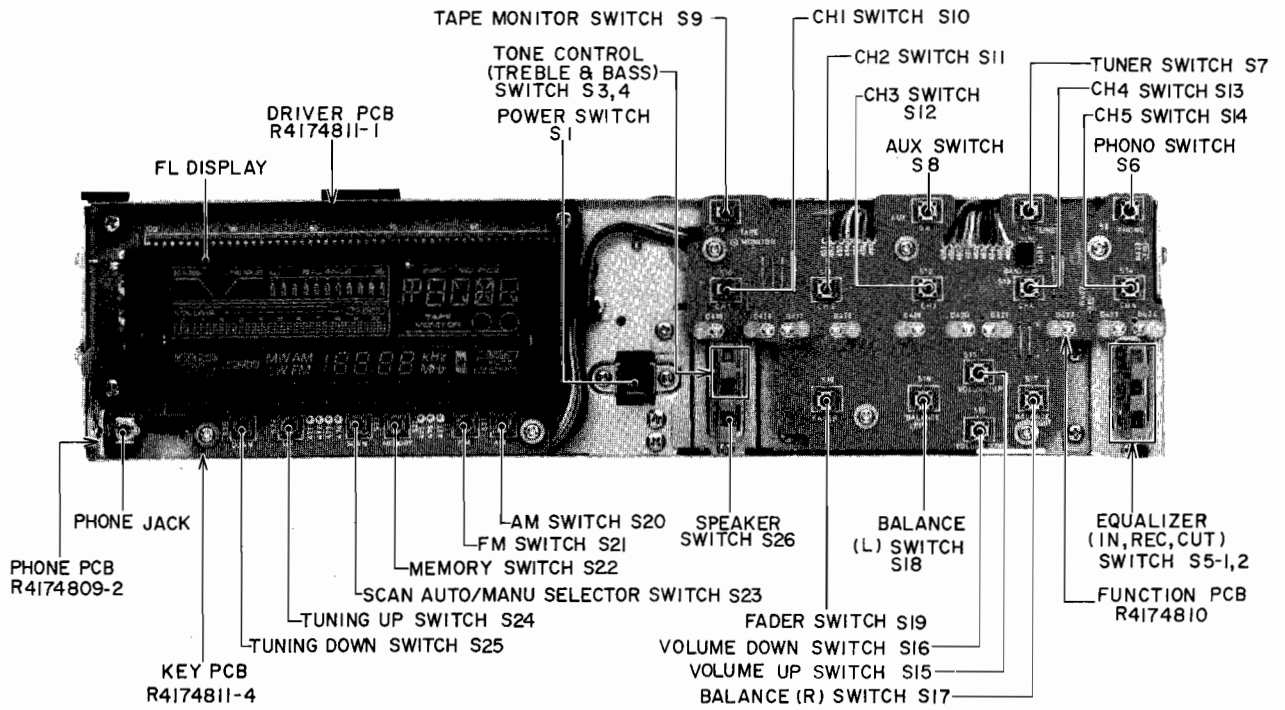

Fig. 4-1 Front View

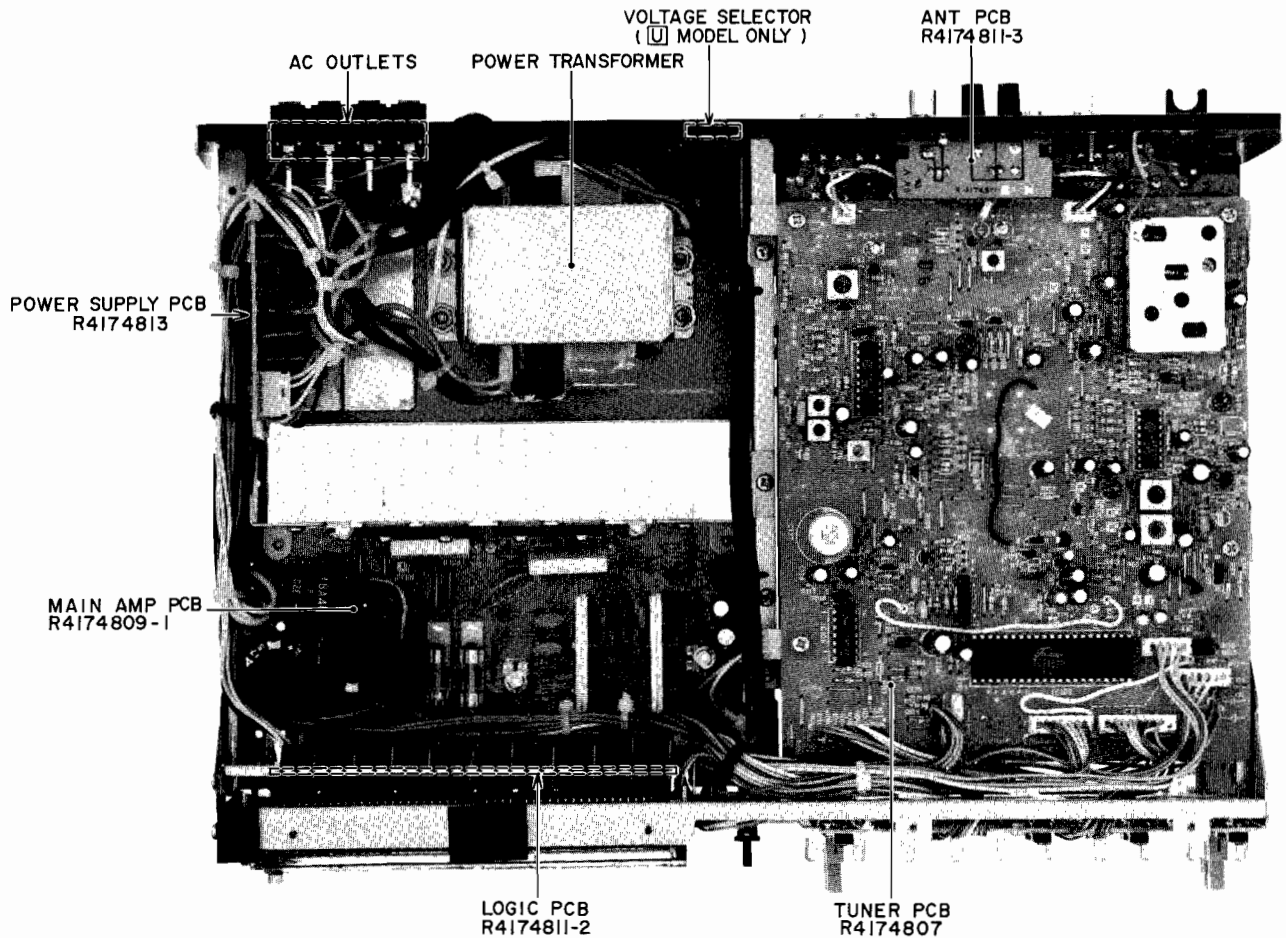

Fig. 4-2 Top View

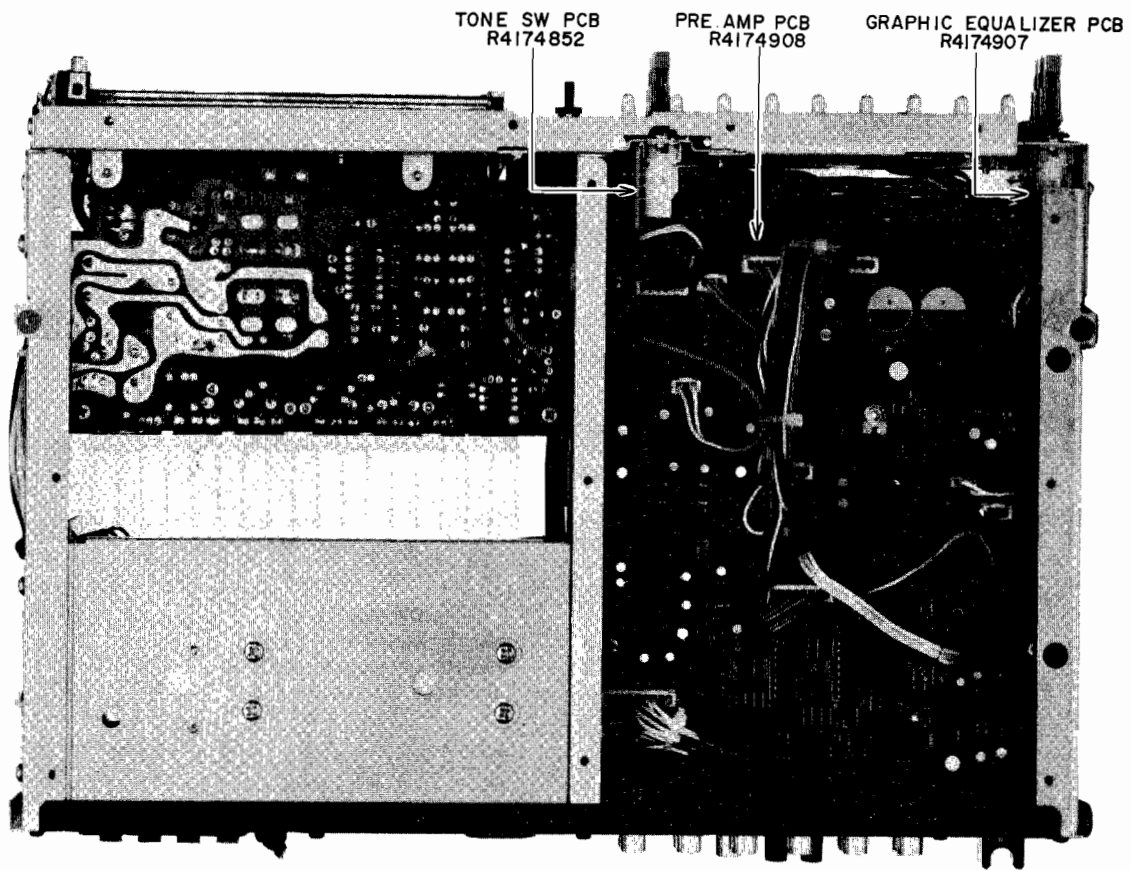

Fig. 4-3 Bottom View

V. TUNER ADJUSTMENT

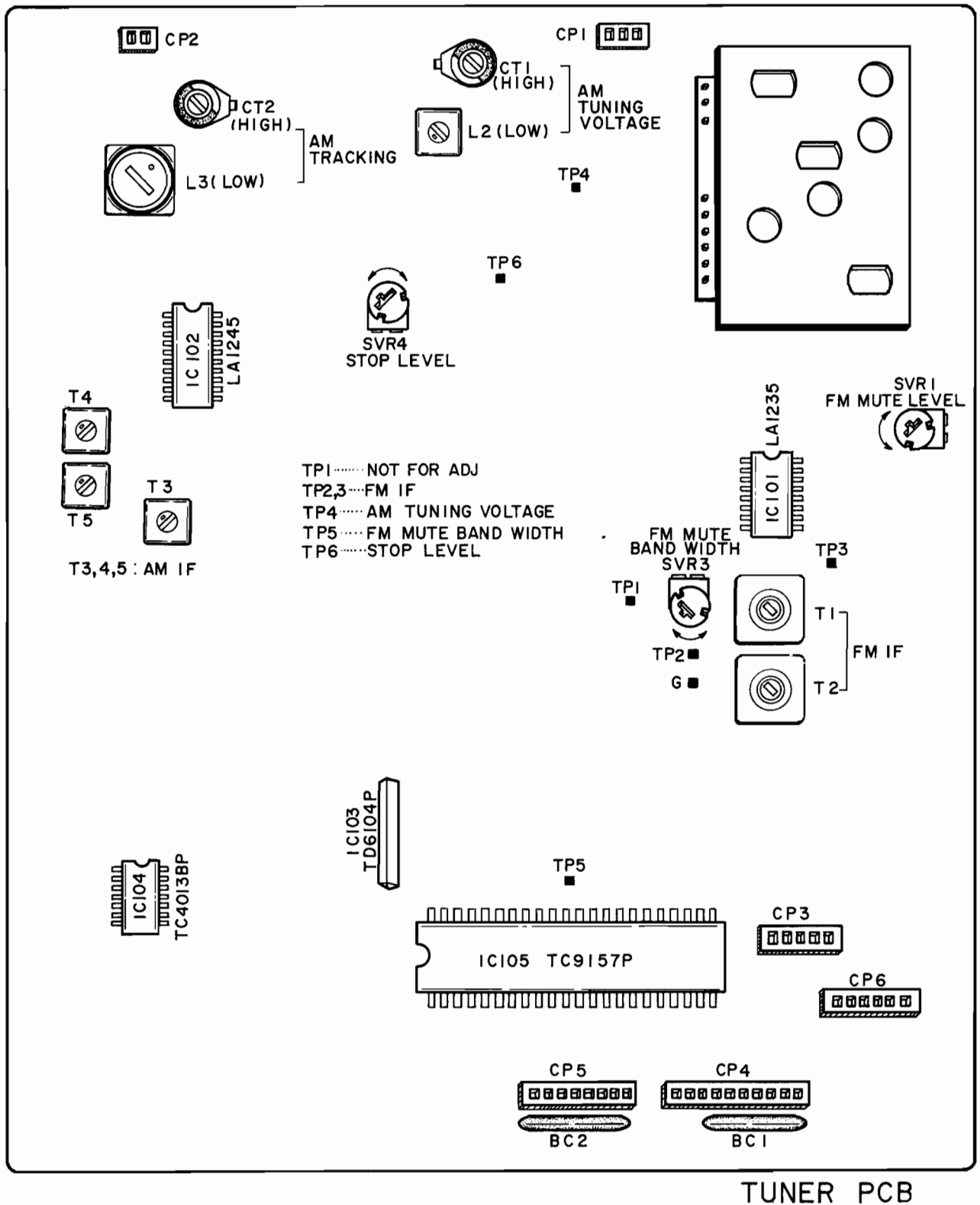
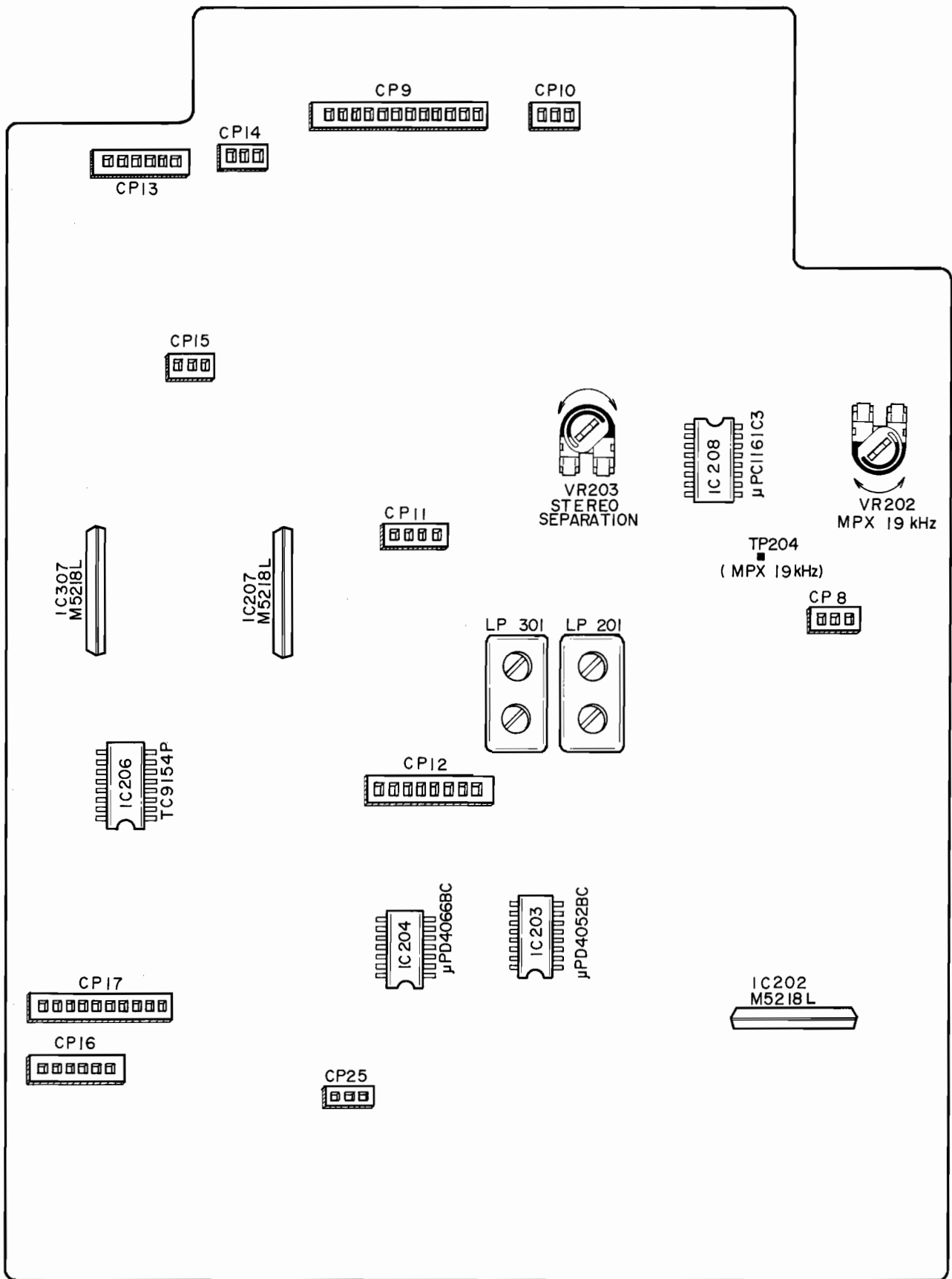

Fig. 5-1 Tuner P.C Board Adjustment Points



PRE AMP PCB

MC-Service

Fig. 5-2 Pre-amp P.C Board Adjustment Points

5-1. AM ADJUSTMENT (Refer to Figs. 5-1 and 5-2)

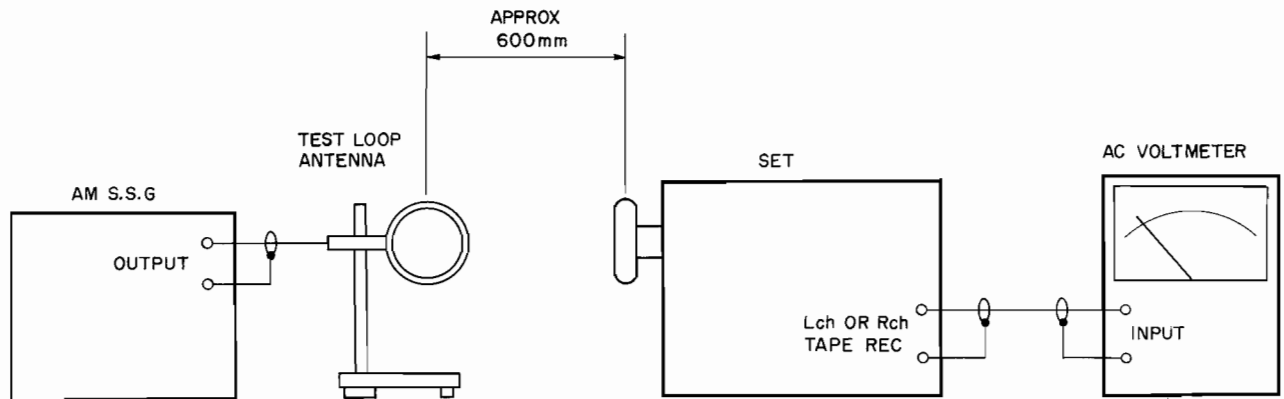
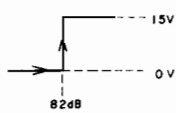

Fig. 5-3 AM Test Instruments Connections

Step	Adjustment Item	Input from SSG	Adjustment Point	Result	Remarks
1	Tuning Voltage		L2	$1.30 \pm 0.05V$	1) BAND to AM. 2) Tuning Display to 522(520) kHz. 3) Connect a Digital Voltmeter (DC RANGE) between TP-4 and GND.
			CT-1	$7.90 \pm 0.1V$	1) Tuning Display to 1611(1610) kHz.
2	AM IF	450 kHz 120 dB	T3 T4 T5	Maximum Output	1) Tuning Display to 522(520) kHz. 2) Connect an AC Voltmeter to TAPE REC Terminal. 3) Adjust T3, T4 and T5 Alternately.
3	Low Range Sensitivity	603(600)kHz 50 dB	L3	Maximum Output	1) Tuning Display to 603(600) kHz. 2) Connect an AC Voltmeter to TAPE REC Terminal.
4	High Range Sensitivity	1404(1400)kHz 50 dB	CT-2	Maximum Output	1) Tuning Display to 1404(1400) kHz. 2) Connect an AC Voltmeter to TAPE REC Terminal.
5	Stop Level	999 kHz 1000 kHz 1008 kHz (See Note 2)	SVR4		1) Tuning Display to 999 kHz, 1000 kHz, or 1008 kHz. (See Note 2) 2) Connect a Digital Voltmeter (DC RANGE) between TP6 and GND. 3) Adjust SVR4 to the point which the voltage rises from 0V to 15V.

- NOTE:**
- The Frequencies indicated in () are for USA and Canada Models.
 - 999 kHz for Japan Model
1000 kHz for USA and Canada Models
1008 kHz for Europe and Australia Models
 - The modulation rate of SSG is 30%.

5-2. FM ADJUSTMENT (Refer to Figs. 7, 8 and 10)

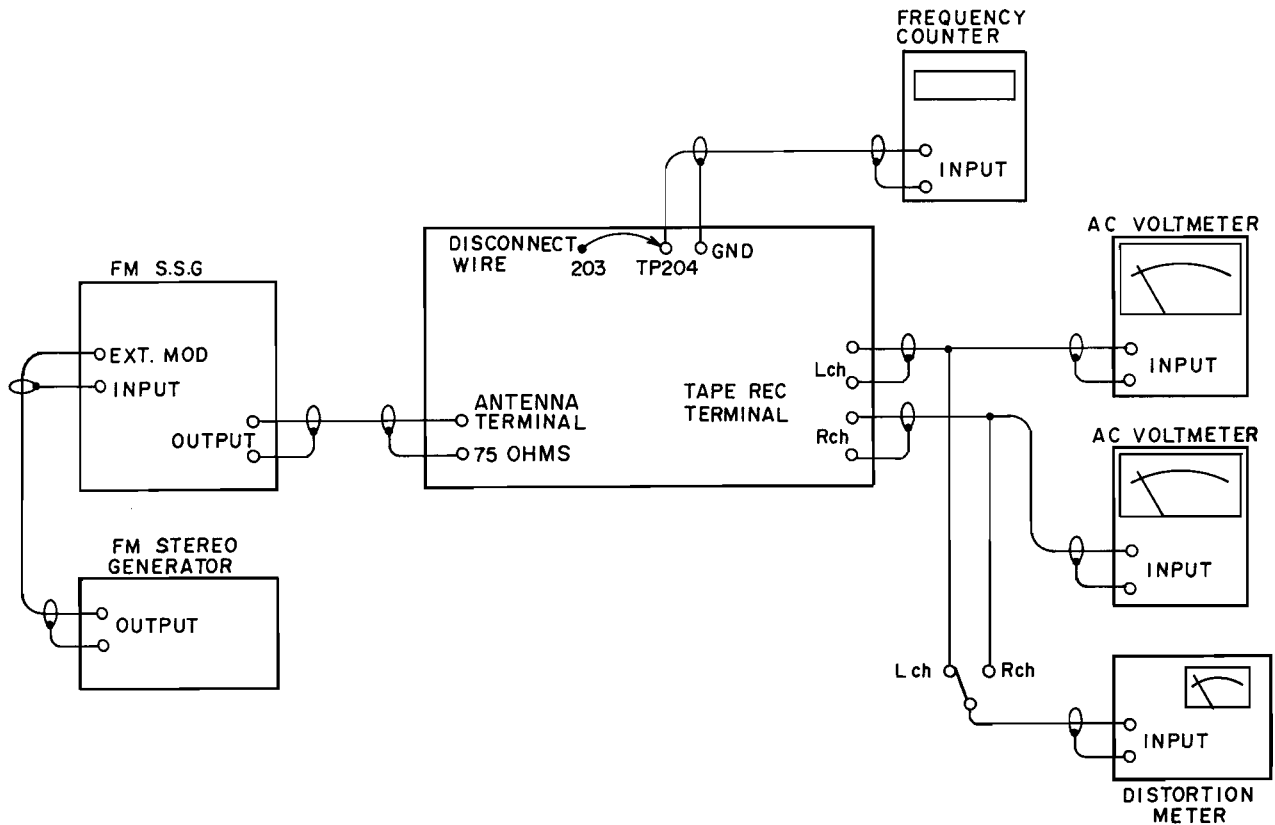

Fig. 5-4 FM Test Instruments Connections

Step	Adjustment Item	Input from SSG	Adjustment Point	Result	Remarks
1	FM IF	98.00(83.00)MHz 66 dB	T1	0 ± 5 mV	1) BAND to FM. 2) Turn the SVR3 fully clockwise. 3) Tuning Display to 98.00(83.00) MHz. 4) Connect a Digital Voltmeter between TP2 and TP3. 5) Connect a Distortion meter to TAPE REC Terminal.
			T2	Minimum Distortion	
2	MUTE Level Auto Stop Detection Signal	98.00(83.00)MHz 18 dB	SVR1		1) Tuning Display to 98.00(83.00) MHz. 2) Connect a DC Voltmeter between TP5 and GND. 3) Adjust SVR1 to the point which the voltage drops from 4.8V to 0V.

Step	Adjustment Item	Input from SSG	Adjustment Point	Result	Remarks
3	FM Mute Band with	98.00(83.00)MHz 60 dB	SVR3		<ol style="list-style-type: none"> 1) Connect a DC Voltmeter between TP-5 and GND. 2) Adjust SVR3 so that the voltage rises from 0V to 4.8V when changing the Tuning Display from 97.90(82.90) MHz to 97.95(82.95) MHz. 3) Confirm that the voltage also rises from 0V to 4.8V when changing the Tuning Display from 98.10(83.10) MHz to 98.05(83.05) MHz.
4	MPX Free Running Frequency	98.00(83.00)MHz 66 dB MONO Modulation 0%	VR202 (Pre-Amp P.C Board)	19.0 ± 0.1 kHz	<ol style="list-style-type: none"> 1) Tuning Display to 98.00(83.00) MHz. 2) Disconnect a wire from TP204. 3) Connect a frequency counter between TP204 and GND.
5	Stereo Separation	98.00(83.00)MHz 60 dB 1 kHz (Stereo 100%) Lch. [Rch.] Input	VR203 (Pre-Amp P.C Board)	Rch. [Lch.] output to Minimum	<ol style="list-style-type: none"> 1) Tuning Display to 98.00(83.00) MHz. 2) Connect an AC Voltmeter to TAPE REC Terminal.
6	Auto Stop	97.982(82.982) MHz 60 dB 98.018(83.018) MHz 60 dB	Confirma- tion	Auto Stop at 98.00(83.00)MHz	<ol style="list-style-type: none"> 1) Tuning Mode to AUTO. 2) Push UP button and start searching from lower frequencies. 3) Push DOWN button and start searching from higher frequencies. <p>* If the Tuning Display does not stop at 98.00 (83.00) MHz, Readjust Step 1 and Step 3.</p>

NOTE: 1. The Frequency Indicated in () are for Japan models.
2. The modulation rate of SSG is 75%, except for Step 4.
3. In Step 3, Tuning Mode must be in Manual mode.

5-3. MAIN AMPLIFIER ADJUSTMENT

5-3-1 IDLING CURRENT ADJUSTMENT

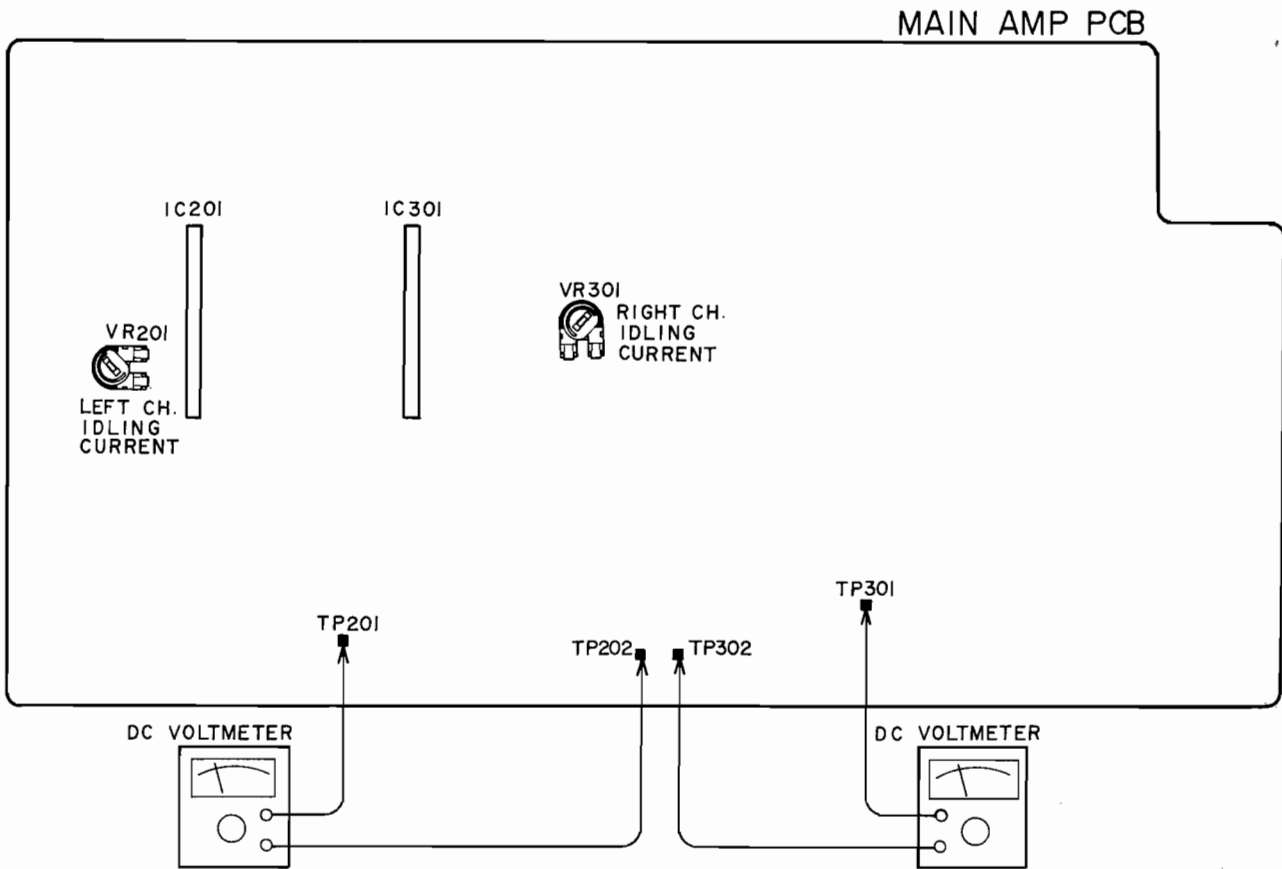

Fig. 5-5 Main Amplifier Adjustment Point

Adjustment Item	Test Point	Adjustment Point	Result	Remarks
Idling Current	TP201, TP202 (LEFT CH.)	VR201	8 mV	1) Set to Function = AUX, Volume = minimum, SP Load = none, 2) Connect a DC Voltmeter between TP201 and TP202.
	TP301, TP302 (RIGHT CH.)	VR301	8 mV	3) Connect a DC Voltmeter between TP301 and TP302.

VI. CLASSIFICATION OF VARIOUS P.C BOARDS

6-1. P.C BOARD TITLES AND IDENTIFICATION NUMBERS

P.C Board Title	P.C Board Number
TUNER P.C Board	R4174807
PRE AMP P.C Board	R4174908
MAIN AMP P.C Board	R4174809-1
POWER SUPPLY P.C Board	R4174813
DRIVE P.C Board	R4174811-1
LOGIC P.C Board	R4174811-2
FUNCTION P.C Board	R4174810
G-EQUALIZER P.C Board	R4174907
TONE SW P.C Board	R4174852
KEY P.C Board	R4174811-4
ANT P.C Board	R4174811-3
PHONE P.C Board	R4174809-2
LINE FILTER P.C Board <input type="checkbox"/> only	R4174869

6-2. COMPOSITION OF VARIOUS P.C BOARDS

1) TUNER P.C BOARD (R4174807), KEY P.C BOARD (R4174811-4), ANT P.C BOARD (R4174811-3)

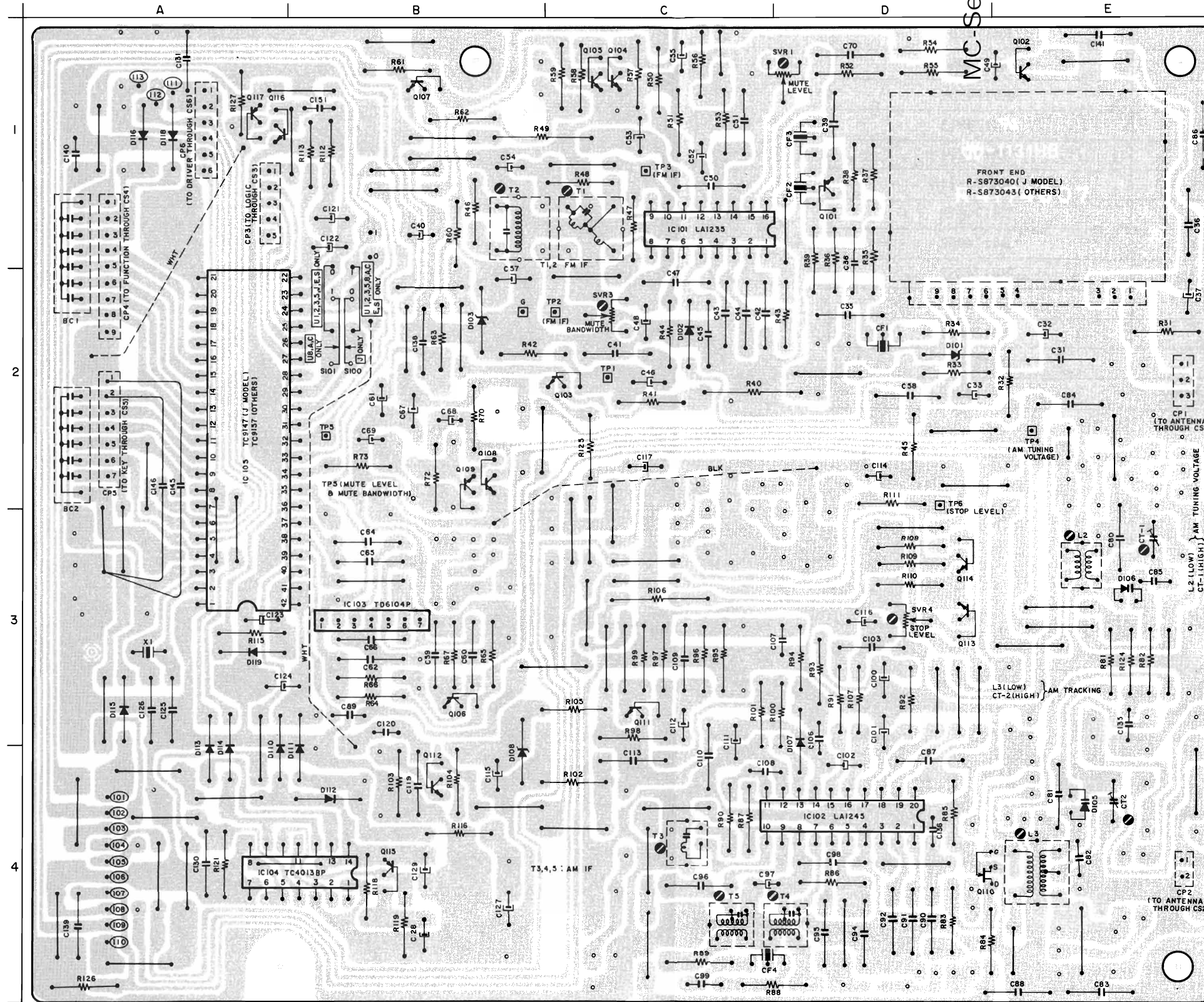
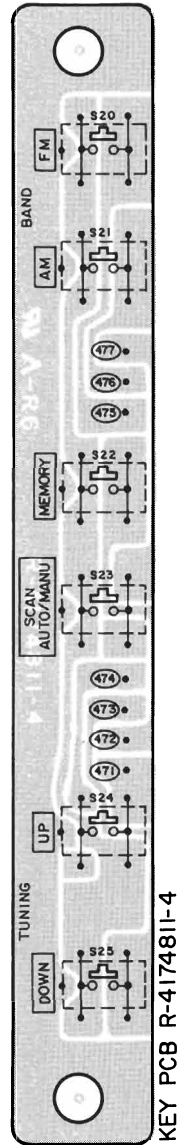

MC-Service

LOCATION OF COMPONENTS

- IC
- IC101.....1C
- IC102.....4D
- IC103.....3B
- IC104.....4B
- IC105.....2A

- TR
- Q101.....1D
- Q102.....1E
- Q103.....2C
- Q104,105.....1C
- Q106.....3B
- Q107.....1B
- Q108,109.....2B
- Q110.....4E
- Q111.....3C
- Q112.....4B
- Q113,114.....3D
- Q115.....4B
- Q116,117.....1A

- TERMINAL
- CP1.....2E
- CP2.....4E
- CP3,4,6.....1A
- CP5.....2A
- ⑩1 to ⑩10 ...4A
- ⑩11 to ⑩13 ...1A

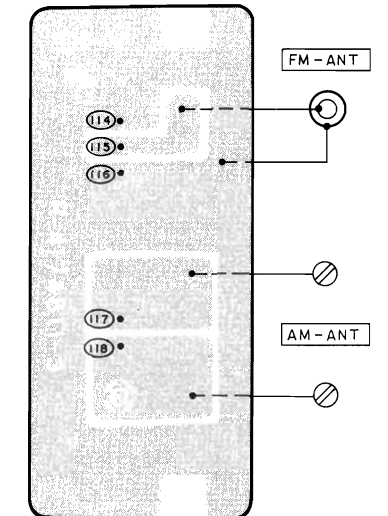

ANT PCB R-4174811-3

- Q101, 106 -----2SC930E-SP
- Q102, 104, 105, 108
- 109, 113, 114 -----2SC536G-SP
- Q103, 111, 112 -----2SC536E-SP
- Q107, 116 -----DTCI24F
- Q110 -----2SK161Y
- Q115 -----2SA608E-NP
- Q117 -----DTAI24F

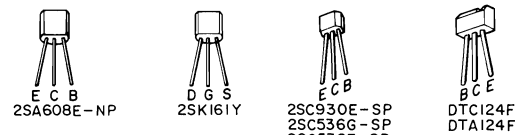

TUNER PCB (R4174807)

MC-Service

2) PRE AMP P.C BOARD (R4174908), TONE SW P.C BOARD (R4174852), G-EQUALIZER P.C BOARD (R4174907)

LOCATION OF COMPONENTS

- TR
- Q204...B2
- Q205...B2
- Q207...D3
- Q208...D4
- Q209...C4
- Q210...C3
- Q211...B2
- Q212...B2
- Q213...A2
- Q214...B3
- Q215...B3
- Q216...B3
- Q217...C4
- Q304...B1
- Q305...B1
- Q307...C3
- IC
- IC202...D4
- IC203...D3
- IC204...D2
- IC206...D1
- IC207...C2
- IC208...B3
- IC307...C1
- TERMINAL
- CP8...C4
- CP9...A2
- CP10...A3
- CP11...C2
- CP12...D2
- CP13...A1
- CP14...A2
- CP15...B1
- CP16...E1
- CP17...D1
- CP24...E3
- CP25...E2

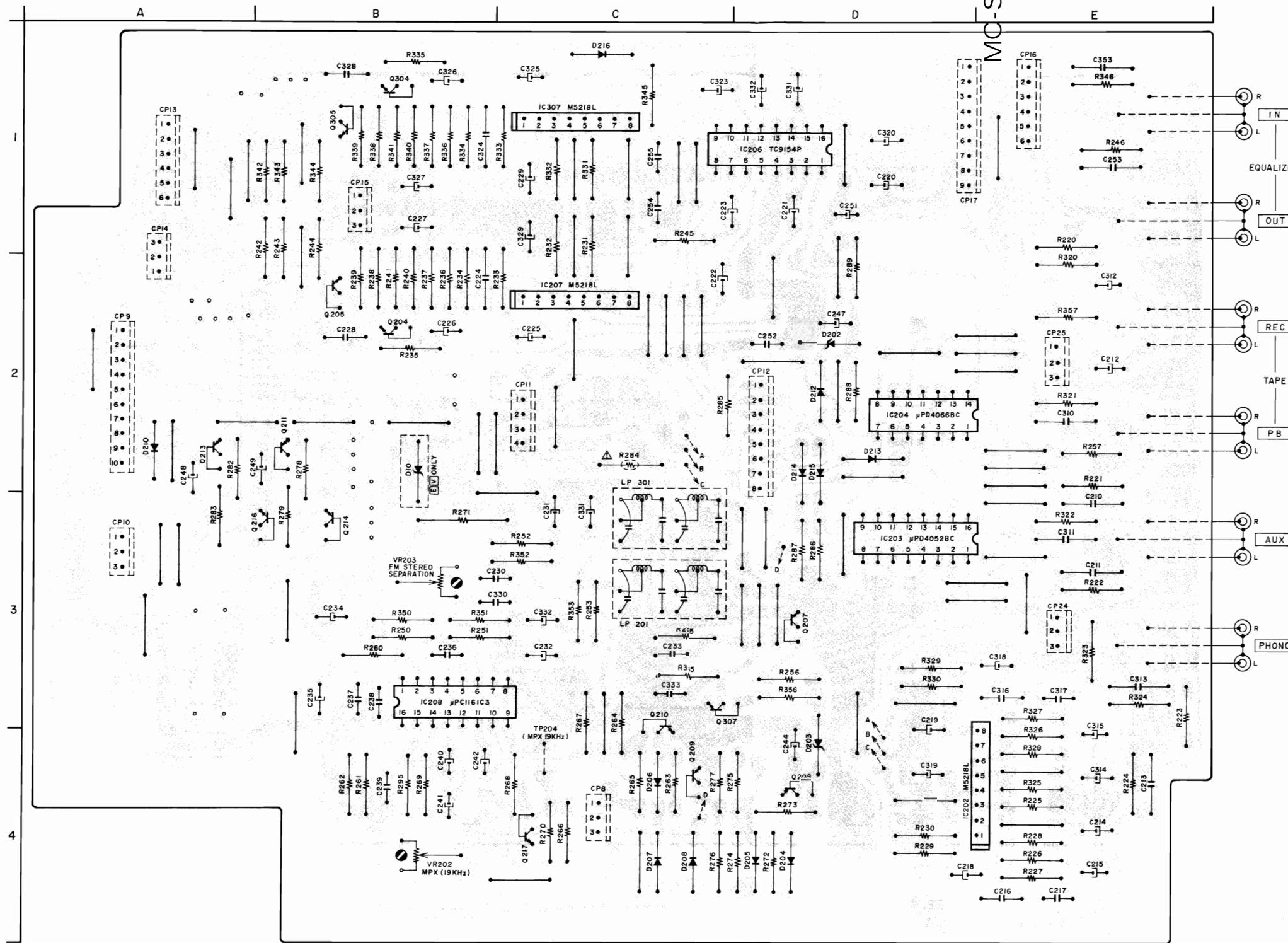

PRE AMP PCB R4174908

G-EQUALIZER PCB R4174907

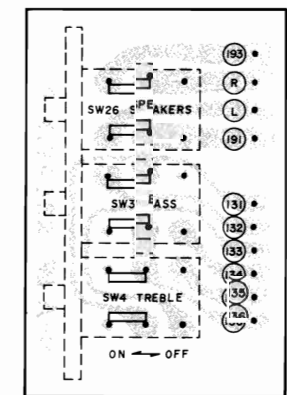
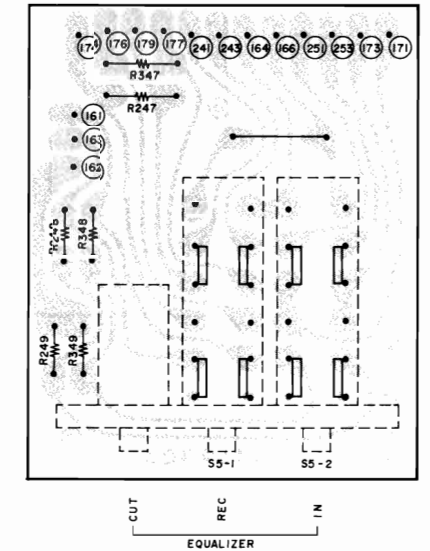

TONE SW PCB R4174852

- Q 204, 205, 304, 305 ----- 2SC536AG
- 209, 210, 217 ----- 2SC536AG
- Q208, 211, 213 ----- 2SA608G
- Q207, 307 ----- 2SC2878B
- Q214, 216 ----- DTC124F



WARNING: Δ INDICATES SAFETY CRITICAL COMPONENTS FOR CONTINUED SAFETY. REPLACE SAFETY CRITICAL COMPONENTS ONLY WITH MANUFACTURER'S RECOMMENDED PARTS.
 AVERTISSEMENT: Δ IL INDIQUE LES COMPOSANTS CRITIQUES DE SÉCURITÉ. POUR MAINTENIR LE DEGRÉ DE SÉCURITÉ DE L'APPAREIL, NE REMPLACER QUE DES PIÈCES RECOMMANDÉES PAR LE FABRICANT.

MC-Service

3) MAIN AMP P.C BOARD (R4174809-1), PHONE P.C BOARD (R4174809-2)

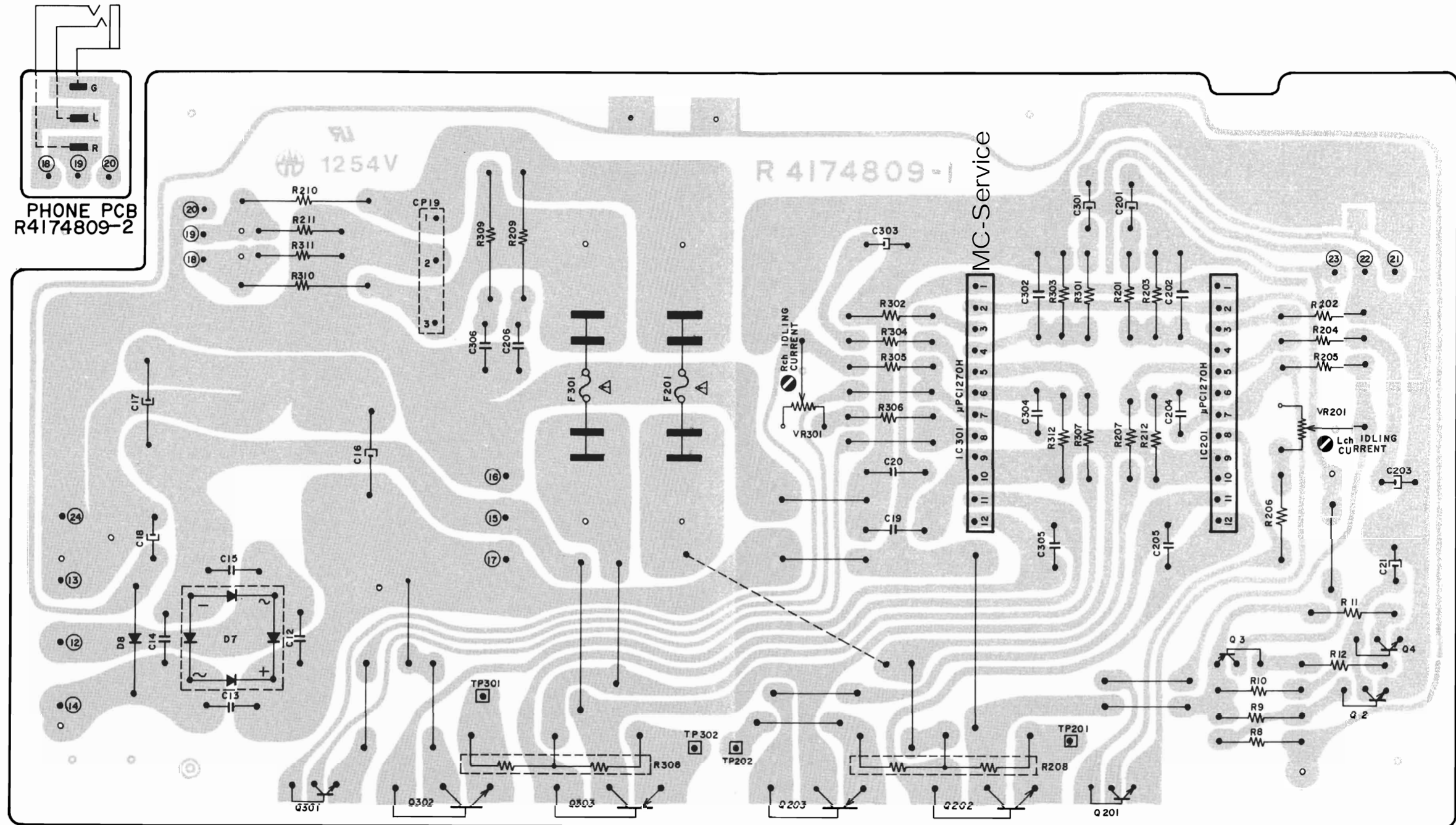

MAIN AMP PCB R4174809-1

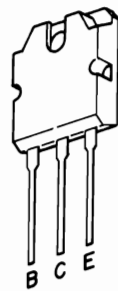

2SD716
2SB686



2SA608KG
2SC2240GR
2SC536KG

- Q2, 4 2SC536KG
- Q3 2SA608KG
- Q201, 301 2SC2240GR
- Q202, 302 2SD716
- Q203, 303 2SB686

WARNING: \triangle INDICATES SAFETY CRITICAL COMPONENTS. FOR CONTINUED SAFETY, REPLACE SAFETY CRITICAL COMPONENTS ONLY WITH MANUFACTURER'S RECOMMENDED PARTS.

AVERTISSEMENT: \triangle IL INDIQUE LES COMPOSANTS CRITIQUES DE SÉCURITÉ. POUR MAINTENIR LE DEGRÉ DE SÉCURITÉ DE L'APPAREIL, NE REMPLACER QUE DES PIÈCES RECOMMANDÉES PAR LE FABRICANT.

MC-Service

4) LOGIC P.C BOARD (R4174811-2)

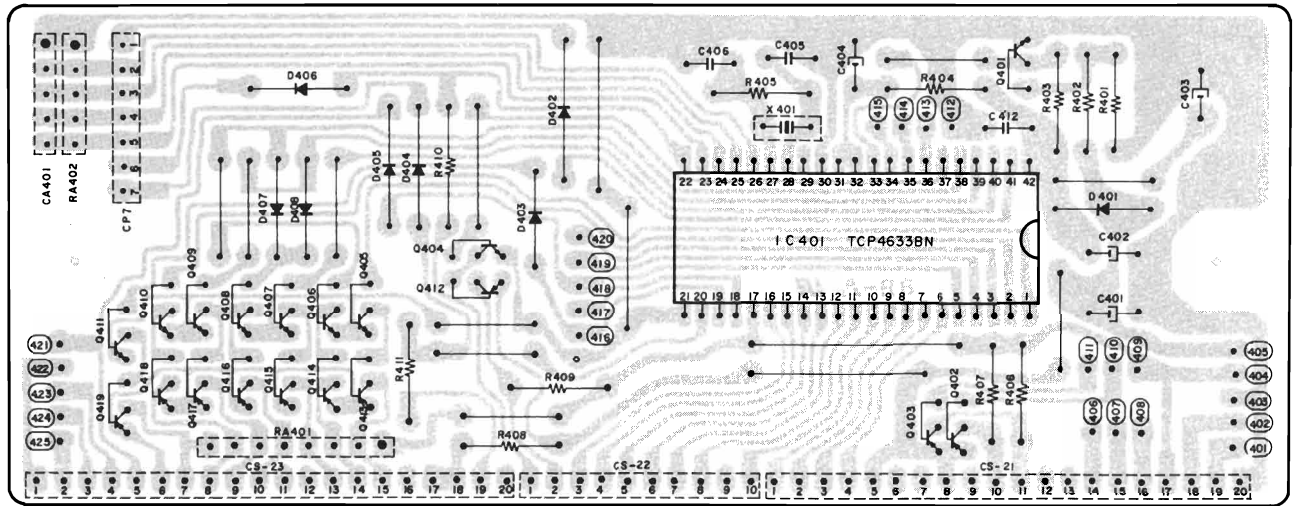

- Q401 2SC536G
- Q402,403,412 to 419 DTA124F
- Q404 to 411 DTC124F

5) FUNCTION P.C BOARD (R4174810-1)

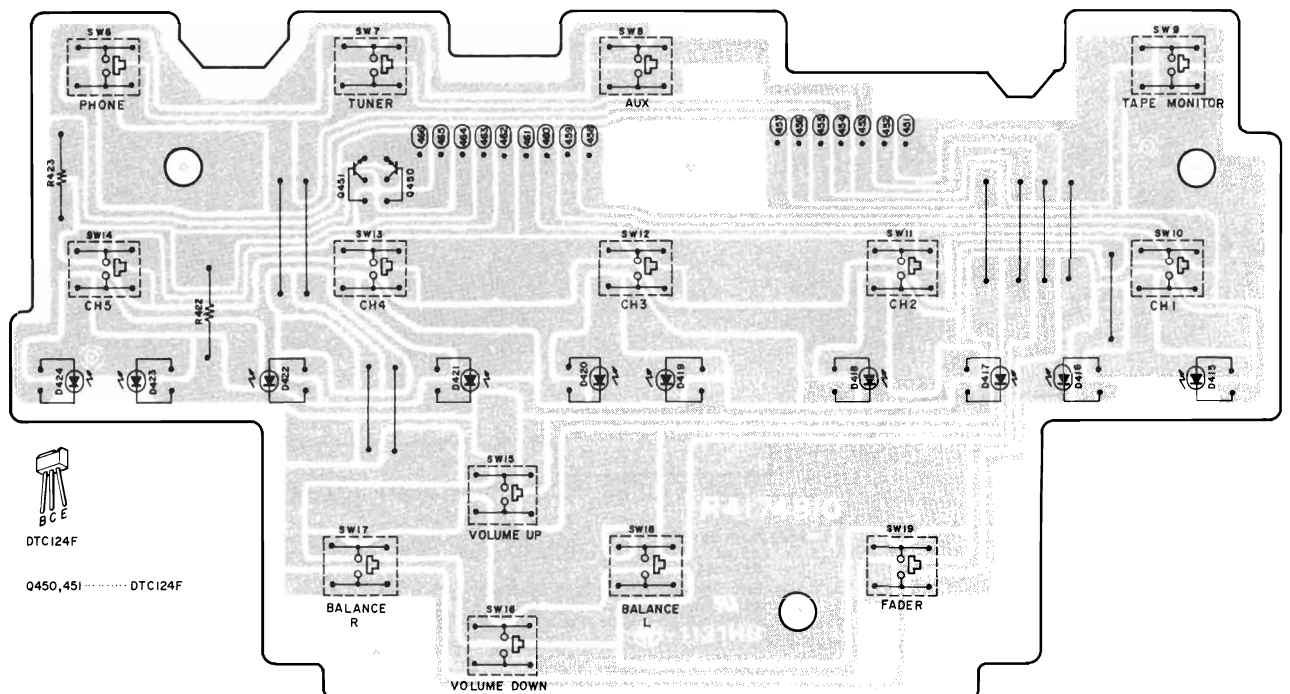

- Q450,451 DTC124F

MC-Service

6) DRIVE P.C BOARD (R4174811-1)

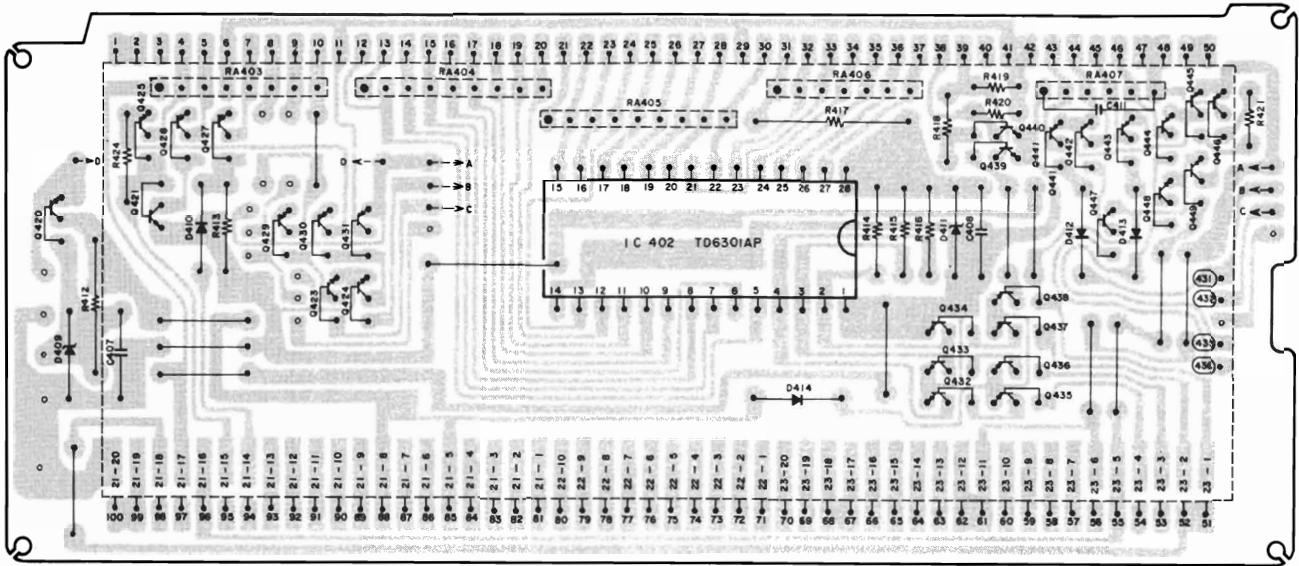

DRIVE PCB R-4174811-I



Q420.....	2SD545G
Q425,426,429 to 431,	
435 to 438, 441 to 445	DTAI24F
Q427, 446.....	2SA608G
Q439, 447 to 449	DTCI24F
Q440.....	2SC536G

7) LINE FILTER P.C BOARD (R4174869) [E] MODEL

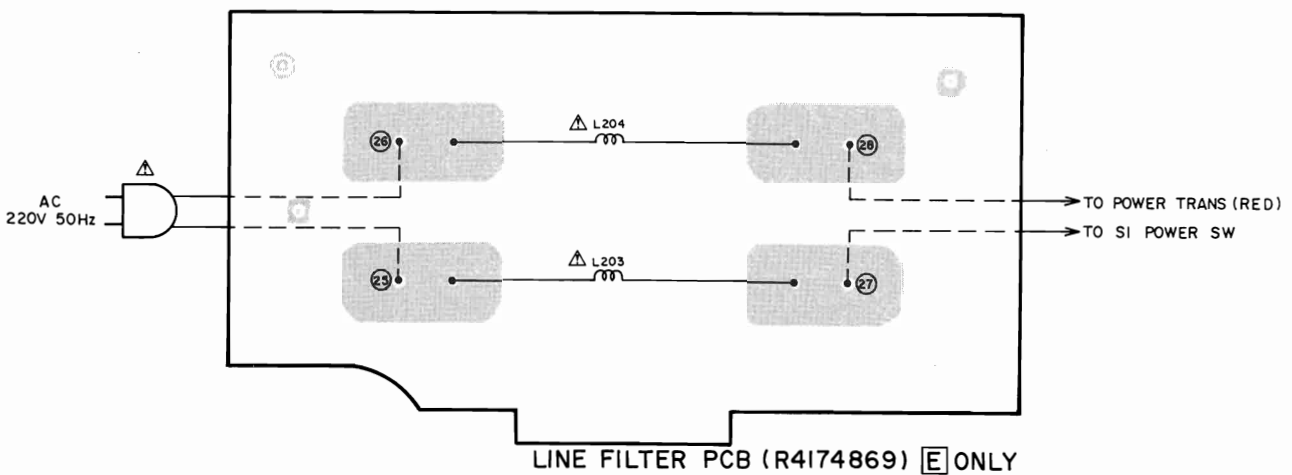

WARNING: Δ INDICATES SAFETY CRITICAL COMPONENTS FOR CONTINUED SAFETY. REPLACE SAFETY CRITICAL COMPONENTS ONLY WITH MANUFACTURER'S RECOMMENDED PARTS

AVERTISSEMENT: Δ IL INDIQUE LES COMPOSANTS CRITIQUES DE SÉCURITÉ. POUR MAINTENIR LE DEGRÉ DE SÉCURITÉ DE L'APPAREIL, NE REMPLACER QUE DES PIÈCES RECOMMANDÉES PAR LE FABRICANT

8) POWER SUPPLY P.C BOARD (R4174813)

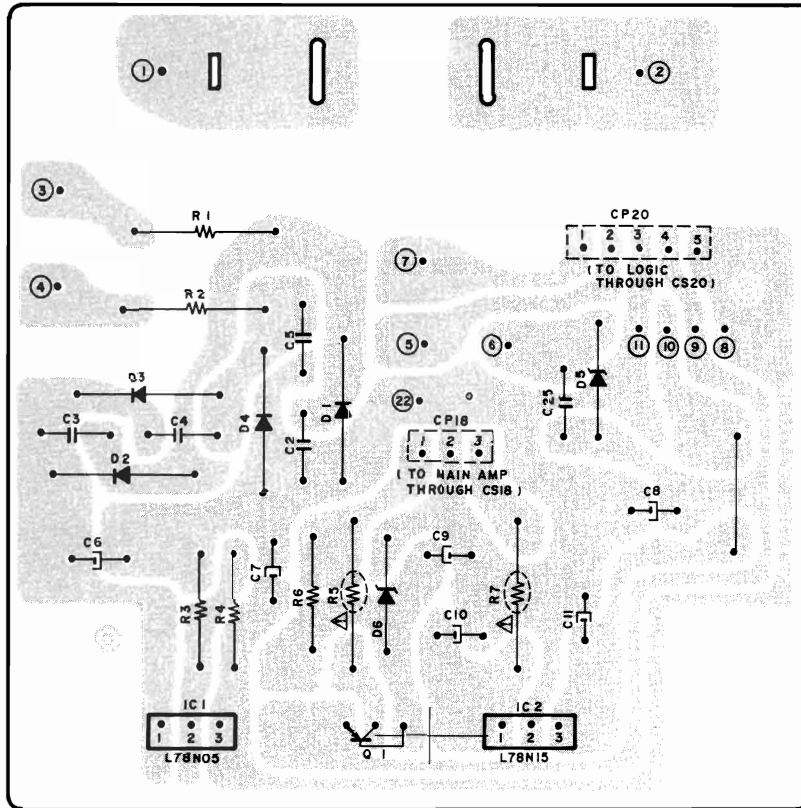

POWER SUPPLY PCB (R4174813) U J A S

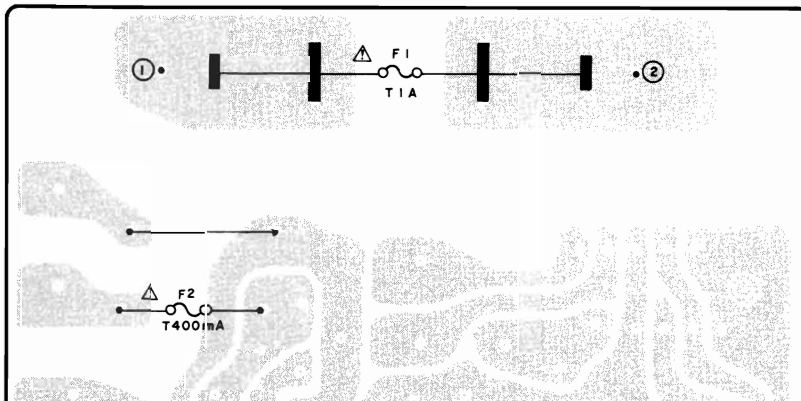

POWER SUPPLY PCB (R4174813) E

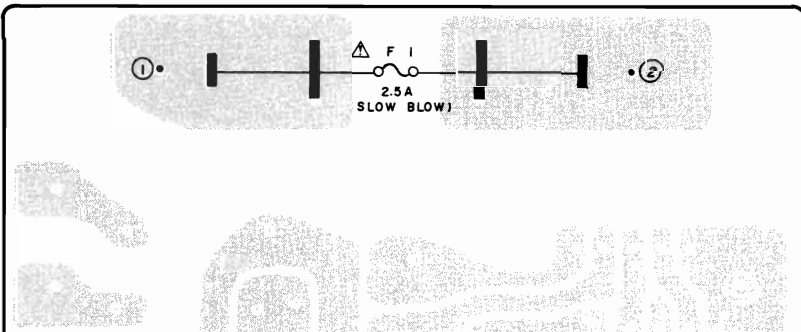

POWER SUPPLY PCB (R4174813) C

WARNING: Δ INDICATES SAFETY CRITICAL COMPONENTS. FOR CONTINUED SAFETY, REPLACE SAFETY CRITICAL COMPONENTS ONLY WITH MANUFACTURER'S RECOMMENDED PARTS

AVERTISSEMENT: Δ IL INDIQUE LES COMPOSANTS CRITIQUES DE SÉCURITÉ. POUR MAINTENIR LE DEGRÉ DE SÉCURITÉ DE L'APPAREIL, NE REMPLACER QUE DES PIÈCES RECOMMANDÉES PAR LE FABRICANT

SECTION 2

PARTS LIST

TABLE OF CONTENTS

RECOMMENDED SPARE PARTS LIST	27
1. TUNER P.C BOARD BLOCK	28
2. DRIVER P.C BOARD BLOCK	28
3. LOGIC P.C BOARD BLOCK	28
4. FUNCTION P.C BOARD BLOCK	28
5. KEY P.C BOARD BLOCK	28
6. PRE AMP P.C BOARD BLOCK	29
7. MAIN AMP P.C BOARD BLOCK	29
8. PHONE P.C BOARD BLOCK	29
9. TONE SW P.C BOARD BLOCK	29
10. G EQUALIZER P.C BOARD BLOCK	29
11. POWER SUPPLY P.C BOARD BLOCK	29
12. LINE FILTER P.C BOARD BLOCK (E Model Only)	29
13. ASSEMBLY BLOCK	30
14. FINAL ASSEMBLY BLOCK	32
INDEX	33

Resistor and Capacitor which is not listed in this parts list, please refer to COMMON LIST FOR SERVICE PARTS.

ATTENTION

1. When placing an order for parts, be sure to list the parts no., model no., and description. There are instances in which if any of this information is omitted, parts cannot be shipped or the wrong parts will be delivered.
2. Please be careful not to make a mistake in the parts no. If the parts no. is in error, a part different from the one ordered may be delivered.
3. Because parts number and parts unit supply in the Preliminary Parts List may be partially changed, please use this parts list for all future reference.

HOW TO USE THIS PARTS LIST

1. This Parts List shows the parts that are considered necessary for repairs. Other parts, such as resistors and capacitors, are shown in the "Common List for Service Parts". Select and order such parts from the "Common List for Service Parts".
2. The Recommended Spare Parts shows those parts in the Parts List which are considered particularly important for service.
3. Parts not shown in the Parts List and "Common List for Service Parts" will not be supplied in principle.
4. How to read list
 - a) Mechanism Block
 - b) P.C Board Block

2. HEAD BASE BLOCK

REF. NO.	PARTS NO.	DESCRIPTION
2-1x	BH-T2023A320A	HEAD BASE BLOCK GX-F66R
2-2	HP-H2206A010A	HEAD R/P PR4-8FU C
2-3	ZS-477876	PAN20x03STL CMT
2-4	ZS-536488	BID20x08STL CMT
2-5	ZG-402895	CS ANGLE ADJUST SPRING

SP (Service Parts) Classification
 A small "x" indicates the inability to show that particular part in the Photo or Illustration.
 This number corresponds with the individual parts index number in that figure
 This number corresponds with the Figure Number

6. SYS. CON. P.C BOARD BLOCK

REF. NO.	PARTS NO.	DESCRIPTION
6-1	BA-T2034A070A	PC SYS CON BLK GX-F44R
6-IC1	EI-324536	IC HD14049BP
6-IC2	EI-336801	IC MB8841-564M
6-IC3	EI-331661	IC SN7405N
6-IC4	EI-336725	IC M54527P
6-TR1to4	ET-200985	TR 2SC2603 F,G
6-TR5to28	ET-554657	TR 2SA733A P,Q
6-D1	ED-318292	D SILICON H 1S2473T-77 T26
6-D2to4	ED-308952	D GERMA V 1K34A-LR F07
6-D5to10	ED-318292	D SILICON H 1S2473T-77 T26
6-X1	EI-318384	OSC X'TAL NC-18C 3.579545MHZ

SP (Service Parts) Classification
 This reference numbers corresponds with symbol numbers of Schematic Diagrams.

5. Both the kind of part and installation position can be determined by the Parts Number. To determine where a parts number is listed, utilize Parts Index at end of Parts List. It is necessary first of all to find the Parts Number. This can be accomplished by using the Reference Number listed at right of parts number in the Parts Index.

WARNING

△ INDICATES SAFETY CRITICAL COMPONENTS. FOR CONTINUED SAFETY, REPLACE SAFETY CRITICAL COMPONENTS ONLY WITH MANUFACTURER'S RECOMMENDED PARTS.

AVERTISSEMENT

△ IL INDIQUE LES COMPOSANTS CRITIQUES DE SURETE. POUR MAINTENIR LE DEGRE DE SECURITE DE L'APPAREIL NE REMPLACER LES COMPOSANTS DONT LE FONCTIONNEMENT EST CRITIQUE POUR LA SECURITE QUE PAR DES PIECES RECOMMANDEES PAR LE FABRICANT.

RECOMMENDED SPARE PARTS

Because, if the parts listed below are on hand, almost any repair can be accomplished, we suggest that you stock these Recommended Spare Parts Items.

NO.	PARTS NO.	DESCRIPTION
1	BT-710961	△ TRANS POWER AA-M3 (A)
2	BT-710960	△ TRANS POWER AA-M3 (C)
3	BT-710962	△ TRANS POWER AA-M3 (E)
4	BT-710959	△ TRANS POWER AA-M3 (J)
5	BT-710963	△ TRANS POWER AA-M3 (S)
6	BT-710958	△ TRANS POWER AA-M3 (U)
7	EC-711085	C COMP
8	EC-711086	C COMP
9	EC-710978	C S-FIX
10	ED-562386	D GERMA H 1S188AM
11	ED-711138	D LED SLP-436B
12	ED-711161	D SILICON DBA40C-K20
13	ED-710913	D SILICON DS135D
14	ED-336805	D SILICON DS135D-KB1 200/1.0A
15	ED-327057	D SILICON H DS442X
16	ED-711092	D VARACTOR SVC321-C2
17	ED-710997	D ZENER GZA16Y
18	ED-710904	D ZENER GZA18Y
19	ED-710988	D ZENER GZA2R3X
20	ED-710978	D ZENER GZA2R7Y
21	ED-710999	D ZENER GZA4R7X
22	ED-710975	D ZENER GZA4R7Y
23	ED-710979	D ZENER GZA5R1Y
24	ED-710986	D ZENER GZA5R6Y
25	EE-710970	FM FRONT END
26	EE-711072	FM FRONT END
27	EF-668474	△ FUSE SEMKO T 250V 0.40A (E)
28	EF-623103	△ FUSE SEMKO T 250V 1A (E)
29	EF-623125	△ FUSE SEMKO T 250V 2.5A (U,E,S)
30	EF-424811	△ FUSE ST6 125V 2.50A (C)
31	EF-424811	△ FUSE ST6 125V 2.50A (J,C,A)
32	EH-710971	FILTER CE (U,J,C,E)
33	EH-710972	FILTER CE (S)
34	EH-711084	FILTER CE
35	EI-337417	IC LA1235
36	EI-202218	IC LA1245
37	EI-711177	IC L78N05
38	EI-711179	IC L78N15
39	EI-337228	IC M5218L0
40	EI-306727	IC TC4013BP
41	EI-344436	IC TC9147P (J)
42	EI-343371	IC TC9154P
43	EI-711089	IC TC9157P(EXCEPT J)
44	EI-711127	IC TCP4633BN
45	EI-344438	IC TD6104P
46	EI-344437	IC TD6301AP
47	EI-707240	IC μPC1161C3
48	EI-711168	IC μPC1270H
49	EI-711149	IC μPD4052BC
50	EI-317653	IC μPD4066C
51	EI-711128	OSC CE 400KHZ
52	EI-711077	OSC X'TAL
53	EM-711114	IND FL FLD
54	EO-711184	△ COIL LF (L203,204)
55	EO-711080	COIL ANT
56	EO-707227	COIL FIX
57	EO-711073	COIL IFT
58	EO-711074	COIL IFT
59	EO-711082	COIL IFT
60	EO-711083	COIL IFT
61	EO-711081	COIL OSC
62	ER-711169	△ R FUSE H 1/2W 4R7J (E,B)
63	ER-710901	△ R FUSE 330J (EXCEPT E)
64	ER-710911	△ R FUSE 5R6J (E)
65	ER-707231	FILTER
66	ER-711117	R COMP
67	ER-711118	R COMP
68	ER-711183	R FUSE H 220J
69	ER-711076	R S-FIX

NO.	PARTS NO.	DESCRIPTION
70	ES-711056	△ SW PUSH (S1)
71	ES-710966	△ SW ROTARY AA-M3 (S2) (U)
72	ES-711172	SW PUSH 3 THROW (S3,4,36)
73	ES-711173	SW PUSH 3 THROW (S5)
74	ES-336780	SW TACT KHH10902
75	ET-711116	TR DTA124F
76	ET-711091	TR DTC124F
77	ET-711094	TR FET 2SK161Y
78	ET-322778	TR 2SA608K-NP E,F,G
79	ET-322244	TR 2SA608K-NP F,G
80	ET-327714	TR 2SB631K F
81	ET-310165	TR 2SB686 R,O AKAI
82	ET-307195	TR 2SC2240 GR,BL
83	ET-338410	TR 2SC2878 A,B
84	ET-316643	TR 2SC536K-NP F,G
85	ET-246846	TR 2SC536NP E,F,G,H
86	ET-328265	TR 2SC930 F
87	ET-318604	TR 2SD545NP E,F
88	ET-310166	TR 2SD716 R,O AKAI
89	EV-707236	R S-FIX 103
90	EV-710994	R S-FIX 501
91	EV-710985	R S-FIX 504

1. TUNER P.C BOARD BLOCK

REF. NO.	PARTS NO.	DESCRIPTION
1-1U	BA-710967	PC TUNER BLK AA-M3(U) (U8,C,A)
1-1E	BA-710969	PC TUNER BLK AA-M3(E) (U1,2,3,5,E,S)
1-1J	BA-710968	PC TUNER BLK AA-M3(J)
1-IC101	EI-337417	IC LA1235
1-IC102	EI-202218	IC LA1245
1-IC103	EI-344438	IC TD6104P
1-IC104	EI-306728	IC TC5080P
1-IC105	EI-711089	IC TC9157P (EXCEPT J)
1-IC105	EI-344436	IC TC9147P (J)
1-Q101	ET-328265	TR 2SC930 F
1-Q102to105	ET-246846	TR 2SC536NP E,F,G,H
1-Q106	ET-328265	TR 2SC930 F
1-Q107	ET-711091	TR DTC124F
1-Q108,109	ET-246846	TR 2SC536NP E,F,G,H
1-Q110	ET-711094	TR FET 2SK161Y
1-Q111to114	ET-246846	TR 2SC536NP E,F,G,H
1-Q115	ET-322778	TR 2SA608K-NP E,F,G
1-Q116	ET-711091	TR DTC124F
1-Q117	ET-711116	TR DTA124F
1-D101	ED-710974	D ZENER GZA8R2Y
1-D102	ED-327057	D SILICON H DS442X
1-D103	ED-710975	D ZENER GZA4R7Y
1-D105,106	ED-711092	D VARACTOR SVC321-C2
1-D107	ED-562386	D GERMA H 1S188AM
1-D108	ED-710975	D ZENER GZA4R7Y
1-D109	ED-327057	D SILICON H DS442X
1-E110U	ED-710913	D SILICON DS135D (U,C)
1-D110J	ED-710903	D SILICON DS130D (J,E,S)
1-D111to119	ED-327057	D SILICON H DS442X
1-L2	EO-711081	COIL OSC
1-L3	EO-711080	COIL ANT
1-T1	EO-711073	COIL IFT
1-T2	EO-711074	COIL IFT
1-T3	ER-707231	FILTER
1-T4	EO-711082	COIL IFT
1-T5	EO-711083	COIL IFT
1-CF1U	EH-710971	FILTER CE (U,J,C,E)
1-CF1S	EH-710972	FILTER CE (S)
1-CF2U	EH-710971	FILTER CE (U,J,C,E)
1-CF2S	EH-710972	FILTER CE (S)
1-CF3U	EH-710971	FILTER CE (U,J,C,E)
1-CF3S	EH-710972	FILTER CE (S)
1-CF4	EH-711084	FILTER CE
1-CA1	EC-711085	C COMP
1-CA2	EC-711086	C COMP
1-CT1,2	EC-710973	C S-FIX
1-SVR1	ER-711076	R S-FIX
1-SVR3,4	ER-711076	R S-FIX
1-X1	EI-711077	OSC X'TAL
1-2U	EE-711072	FM FRONT END
1-2J	EE-710970	FM FRONT END
1-R40	ER-336919	R OMF H SNP FS 1W 121J
1-R49	ER-324251	R OMF H FS 1W 101J
1-R106	ER-324251	R OMF H FS 1W 101J
1-C85	EC-314996	C STY V SNP CQFS 391J 50DC
1-C127	EC-344157	C DOUBLE LAYER 473Z 5.5DC

2. DRIVER P.C BOARD BLOCK

REF. NO.	PARTS NO.	DESCRIPTION
2-1	BA-710977	PC DRIVER BLK AA-M3
2-IC402	EI-344437	IC TD6301AP
2-Q420	ET-318604	TR 2SD545NP E,F
2-Q421	ET-711091	TR DTC124F
2-Q423,424	ET-711091	TR DTC124F
2-Q425,426	ET-711116	TR DTA124F
2-Q427	ET-322778	TR 2SA608K-NP E,F,G
2-Q429to431	ET-711116	TR DTA124F
2-Q432to434	ET-711091	TR DTC124F
2-Q435to438	ET-711116	TR DTA124F
2-Q439	ET-711091	TR DTC124F
2-Q441to445	ET-711116	TR DTA124F
2-Q446	ET-322778	TR 2SA608K-NP E,F,G
2-Q447to449	ET-711091	TR DTC124F
2-D409	ED-710978	D ZENER GZA2R7Y
2-D410	ED-327057	D SILICON H DS442X
2-D411	ED-710979	D ZENER GZA5R1Y
2-D412,413	ED-327057	D SILICON H DS442X
2-RA403	ER-711118	R COMP
2-RA404,405	ER-711117	R COMP
2-RA406	ER-711119	R COMP
2-RA407	ER-711120	R COMP
2-FLD	EM-711114	IND FL

3. LOGIC P.C BOARD BLOCK

REF. NO.	PARTS NO.	DESCRIPTION
3-1	BA-710980	PC LOGIC BLK AA-M3
3-IC401	EI-711127	IC TPC4633BN
3-Q401	ET-246846	TR 2SC536NP E,F,G,H
3-Q402,403	ET-711116	TR DTA124F
3-Q404to411	ET-711091	TR DTC124F
3-Q412to419	ET-711116	TR DTA124F
3-D401	ED-710913	D SILICON DS135D
3-D402to407	ED-327057	D SILICON H DS442X
3-X401	EI-711128	OSC CE 400KHZ
3-RA401	ER-711118	R COMP
3-RA402	ER-711129	R COMP
3-CA401	EC-7111130	COMP
3-C403	EC-344157	C DOUBLE LAYER 473Z 5.5DC

4. FUNCTION P.C BOARD BLOCK

REF. NO.	PARTS NO.	DESCRIPTION
4-Q450,451	ET-711091	TR DTC124F
4-Q415to424	ED-711138	D LED SLP-436B
4-S6to19	ES-336780	SW TACT KHH10902

5. KEY P.C BOARD BLOCK

REF. NO.	PARTS NO.	DESCRIPTION
5-S20to25	ES-336780	SW TACT KHH10902

MC-Service

6. PRE AMP P.C BOARD BLOCK

REF. NO.	PARTS NO.	DESCRIPTION
6-1U	BA-710981	PC PRE AMP BLK AA-M3(U,C,A)
6-1J	BA-710982	PC PRE AMP BLK AA-M3 (J,S)
6-1E	BA-710983	PC PRE AMP BLK AA-M3 (E)
6-IC202	EI-337228	IC M5218L0
6-IC203	EI-7111149	IC μ PD4052BC
6-IC204	EI-317653	IC μ PD4066C
6-IC206	EI-343371	IC TC9154P
6-IC207	EI-337228	IC M5218L0
6-IC208	EI-707240	IC μ PC1161C3
6-IC307	EI-337228	IC M5218L0
6-Q204,205	ET-246846	TR 2SC536NP E,F,G,H
6-Q207	ET-338410	TR 2SC2878 A,B
6-Q208	ET-322778	TR 2SA608K-NP E,F,G
6-Q209,210	ET-246846	TR 2SC536NP E,F,G,H
6-Q211	ET-322778	TR 2SA608K-NP E,F,G
6-Q213	ET-322778	TR 2SA608K-NP E,F,G
6-Q214	ET-711091	TR DTC124F
6-Q216	ET-711091	TR DTC124F
6-Q217	ET-246846	TR 2SC536NP E,F,G,H
6-Q304,305	ET-246846	TR 2SC536NP E,F,G,H
6-Q307	ET-338410	TR 2SC2878 A,B
6-D10	ED-710904	D ZENER GZA18Y
6-D202	ED-710986	D ZENER GZA5R6Y
6-D203	ED-710988	D ZENER GZA2R3X
6-D204to208	ED-327057	D SILICON H DS442X
6-D210	ED-327057	D SILICON H DS442X
6-D212to217	ED-327057	D SILICON H DS442X
6-LP201	EO-707227	COIL FIX
6-LP301	EO-707227	COIL FIX
6-VR202	EV-707236	R S-FIX 103
6-VR203	EV-710985	R S-FIX 504
6-R271	ER-336919	R OMF H SNP FS 1W 121J
6-C239	EC-330309	C STY F05 CQ09S 511J 50DC
6-2	EJ-711141	PIN JACK 6P
6-C230	EC-314715	C MY V AMX 122J 50DC
6-C330	EC-314715	C MY V AMX 122J 50DC

NOTE: The parts indicated in REF. NO. 6-1U is for 75 μ s FM-EMPHASIS area. For 50 μ s FM-EMPHASIS area, change the value of two capacitors (C230, C330) from 182J to 122J.

7. MAIN AMP P.C BOARD BLOCK

REF. NO.	PARTS NO.	DESCRIPTION
7-1U	BA-710990	PC MAIN AMP BLK AA-M3(U)
7-1J	BA-710991	PC MAIN AMP BLK AA-M3(J)
7-1C	BA-710992	PC MAIN AMP BLK AA-M3(C)(C,A)
7-1E	BA-710993	PC MAIN AMP BLK AA-M3(E)(E,S)
7-IC201	EI-7111168	IC μ PC1270H
7-IC301	EI-7111168	IC μ PC1270H
7-Q2	ET-316643	TR 2SC536K-NP F,G
7-Q3	ET-322244	TR 2SA608K-NP F,G
7-Q4	ET-316643	TR 2SC536K-NP F,G
7-Q201	ET-307195	TR 2SC2240 GR,BL
7-Q202	ET-310166	TR 2SD716 R,O AKAI
7-Q203	ET-310165	TR 2SB686 R,O AKAI
7-Q301	ET-307195	TR 2SC2240 GR,BL
7-Q302	ET-310166	TR 2SD716 R,O AKAI
7-Q303	ET-310165	TR 2SB686 R,O AKAI
7-D7	ED-711161	D SILICON DBA40C-K20
7-D8	ED-336805	D SILICON DS135D-KB1 200/1.0A
7-VR201	EV-710994	R S-FIX 501
7-VR301	EV-710994	R S-FIX 501
7-R208	ER-711159	R COMP
7-R209U	ER-337754	R OMF H S15 FS 1W 100J(U,J,C,A)
7-R209E	ER-711169	Δ R FUSE H 1/2W 4R7J (E,B)
7-R210	ER-303342	R OMF H FS 1W 331J
7-R308	ER-711159	R COMP
7-R309U	ER-337754	R OMF H S15 FS 1W 100J(U,J,C,A)
7-R309E	ER-711169	Δ R FUSE H 1/2W 4R7J (E,B)
7-R310	ER-303342	R OMF H FS 1W 331J

REF. NO.	PARTS NO.	DESCRIPTION
7-C16,17	EC-711170	C EC V 472M 50DC
7-F201U	EF-623125	Δ FUSE SEMKO T 250V 2.5A (U,E,S)
7-F201J	EF-424811	Δ FUSE ST6 125V 2.50A (J,C,A)
7-F301U	EF-623125	FUSE SEMKO T 250V 2.5A (U,E,S)
7-F301J	EF-424811	Δ FUSE ST6 125V 2.50A (J,C,A)

8. PHONE P.C BOARD BLOCK

REF. NO.	PARTS NO.	DESCRIPTION
8-J1	EJ-711171	PHONE J

9. TONE SW P.C BOARD BLOCK

REF. NO.	PARTS NO.	DESCRIPTION
9-1	ES-711172	SW PUSH 3 THROW (S3,4,26)

10. G EQUALIZER P.C BOARD BLOCK

REF. NO.	PARTS NO.	DESCRIPTION
10-1	ES-711173	SW PUSH 3 THROW (S5)

11. POWER SUPPLY P.C BOARD BLOCK

REF. NO.	PARTS NO.	DESCRIPTION
11-IC1	EI-711177	IC L78N05
11-IC2	EI-711179	IC L78N15
11-Q1	ET-327714	TR 2SB631K F
11-D1to4	ED-336805	D SILICON DS135D-KB1 200/1.0A
11-D5	ED-710999	D ZENER GZA4R7X
11-D6	ED-710997	D ZENER GZA16Y
11-R1,2	ER-710900	R CB FS 1R8J
11-R5U	ER-710901	Δ R FUSE 330J (EXCEPT E)
11-R5E	ER-710911	Δ R FUSE 5R6J (E)
11-R7	ER-711183	Δ R FUSE H 220J
11-F1C	EF-424811	Δ FUSE ST6 125V 2.50A (C)
11-F1E	EF-623103	Δ FUSE SEMKO T 250V 1A (E)

12. LINE FILTER P.C BOARD BLOCK (E Model Only)

REF. NO.	PARTS NO.	DESCRIPTION
12-1	EO-711184	Δ COIL LF (L203,204)

ASSEMBLY BLOCK

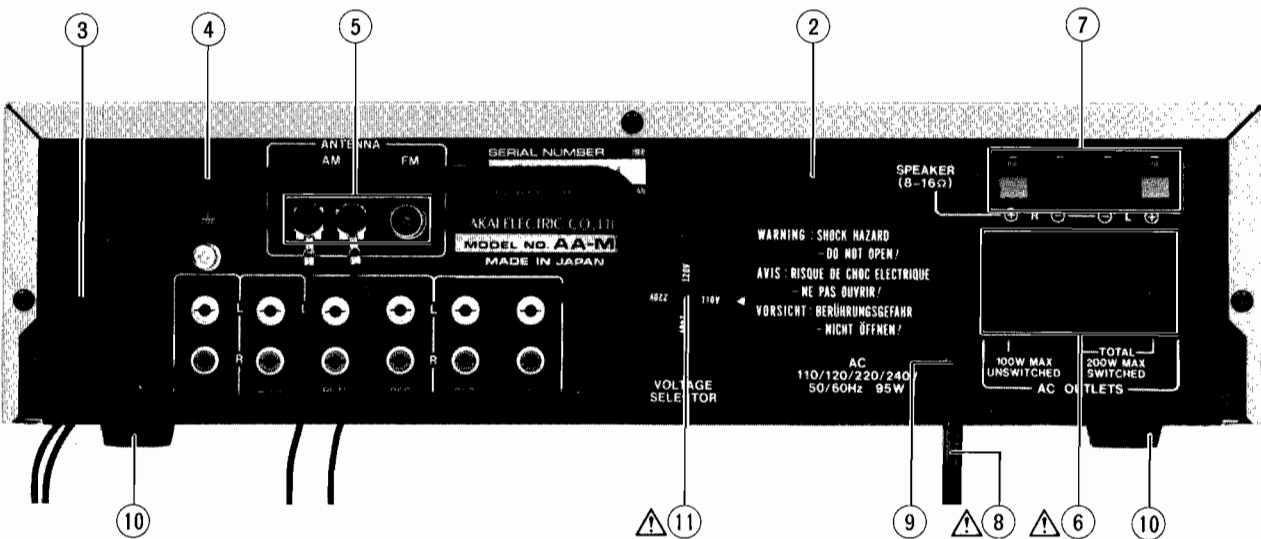
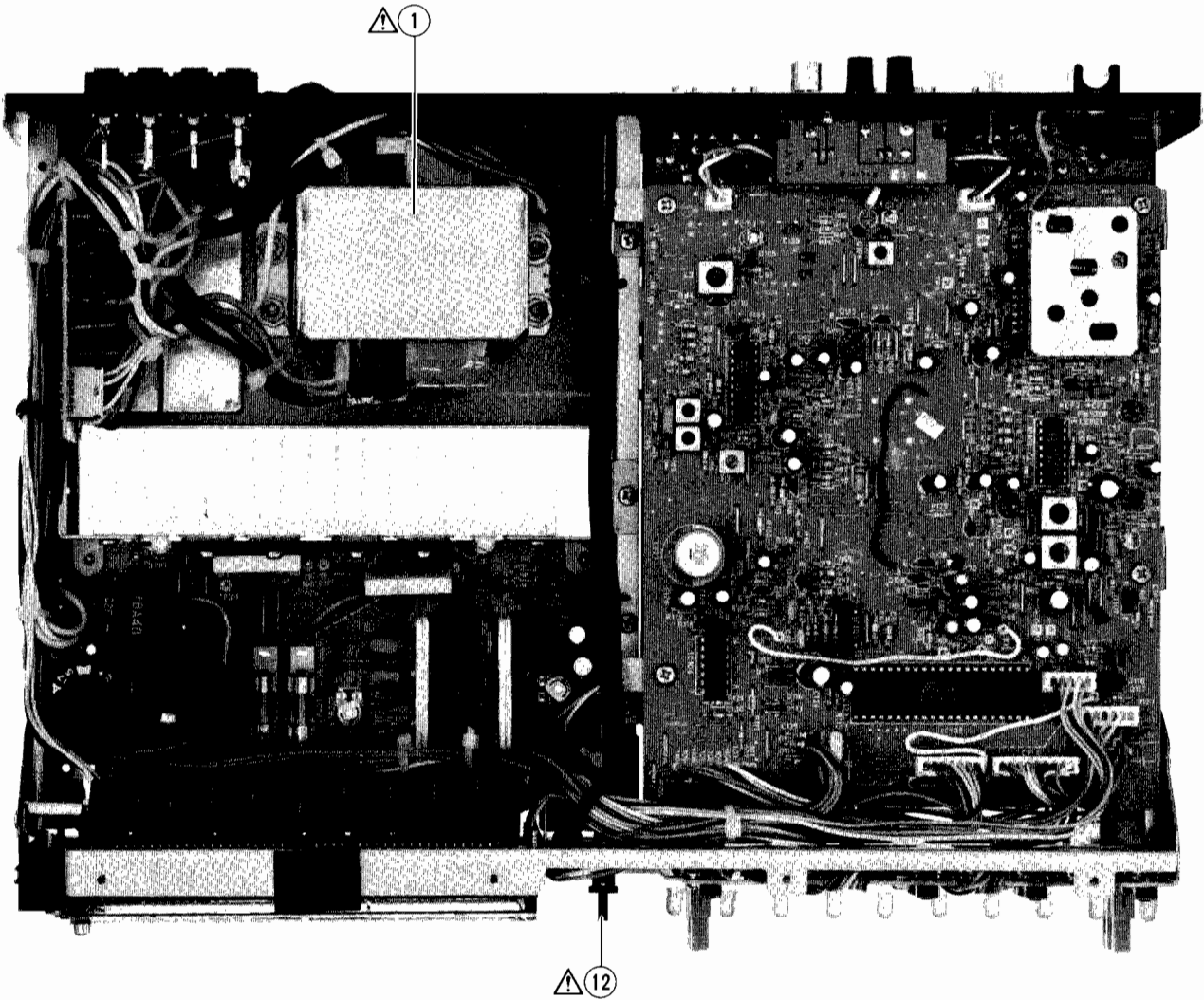

MC-Service

13. ASSEMBLY BLOCK

REF. NO.	PARTS NO.	DESCRIPTION
13-1U	BT-710958	△ TRANS POWER AA-M3 (U)
13-1J	BT-710959	△ TRANS POWER AA-M3 (J)
13-1C	BT-710960	△ TRANS POWER AA-M3 (C)
13-1A	BT-710961	△ TRANS POWER AA-M3 (A)
13-1E	BT-710962	△ TRANS POWER AA-M3 (E)
13-1S	BT-710963	△ TRANS POWER AA-M3 (S)
13-2U	SP-710951	PANEL REAR AA-M3 (U)
13-2J	SP-710952	PANEL REAR AA-M3 (J)
13-2C	SP-710953	PANEL REAR AA-M3 (C)
13-2A	SP-710955	PANEL REAR AA-M3 (A)
13-2E	SP-710956	PANEL REAR AA-M3 (E)
13-2S	SP-710957	PANEL REAR AA-M3 (S)
13-3	SZ-711052	HOLDER ANTENNA
13-4	EE-707211	ANT LOOP (L1)
13-5	EJ-344423	TERMINAL W/SCREW YKD31-0133 P 2P
13-6	EJ-710964	△ SOCKET OUTLET AA-M3
13-7	EJ-711054	△ TERMINAL PUSH 4P
13-8U	EW-306428	△ AC CORD 2 CORES KP-205A, VFF J (U)
13-8J	EW-306427	△ AC CORD 2 CORES KP-211, VFF J (J)
13-8C	EW-343363	△ AC CORD 2 CORES KP-8, SPT-2 UC (C,A)
13-8E	EW-313882	△ AC CORD 2 CORES KP-149C, LTCE-2F E (E)
13-8S	EW-201515	△ AC CORD 2 CORES KP-560, LTSA-2F S (S)
13-9U	EZ-706210	STRAIN RELIEF 2P-4 (U,J)
13-9C	EZ-706319	STRAIN RELIEF (C,A,E,S)
13-10	SA-711043	RUBBER FOOT
13-11	ES-710966	△ SW ROTARY AA-M3 (S2)(U)
13-12	ES-711056	△ SW PUSH (S1)
13-C1U	EC-338411	△ C CE V FZ 103P 400AC (EXCEPT J)
13-C1J	EC-320548	△ C CE V F 103Z 250AC (J)
13-F2	EF-668474	△ FUSE SEMKO T 250V 0.40A (E)

FINAL ASSEMBLY BLOCK

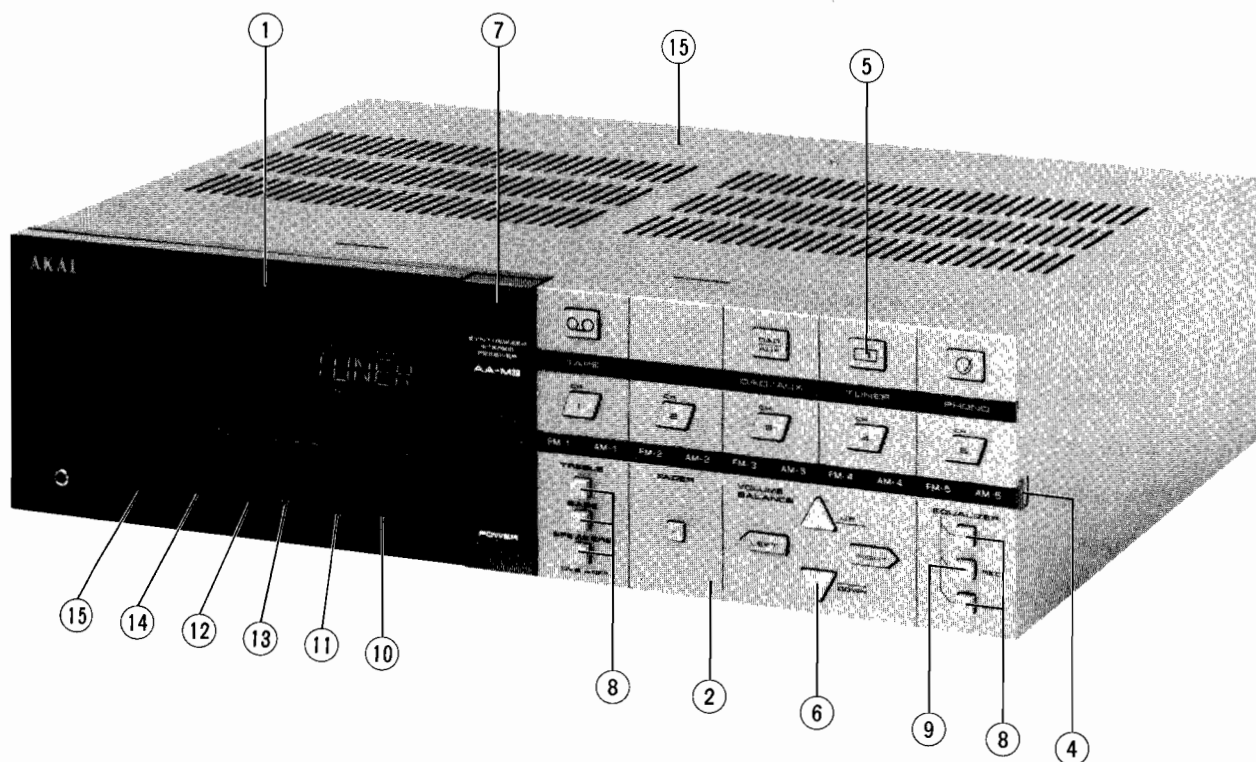

14. FINAL ASSEMBLY BLOCK

REF. NO.	PARTS NO.	DESCRIPTION
14-1	BD-710920	PANEL FRONT BLK (LEFT)
14-2	BD-710919	PANEL FRONT BLK (RIGHT)
14-3X	SZ-345569	BT CTS30x08STL CMT
14-4	SZ-711005	HOLDER FILM
14-5	SK-344798	RUBBER BUTTON SHEET OPERATION (1)
14-6	SK-344799	RUBBER BUTTON SHEET OPERATION (2)
14-7	SK-344330C	KNOB POWER AA-M3
14-8	SK-711007	KNOB FUNCTION
14-9	SK-711008	KNOB FUNCTION
14-10	SK-711009	KNOB AM
14-11	SK-711010	KNOB FM
14-12	SK-711012	KNOB SCAN
14-13	SK-711013	KNOB MEMORY
14-14	SK-711014	KNOB UP
14-15	SK-711015	KNOB DOWN
14-16	SP-710950	COVER UPPER AA-M3
14-17x	EE-315329	ANT DIPOLE AFM-1B (EXCEPT J)
14-18x	EE-320526	ANT DIPOLE AMM-1A (J)
14-19x	EJ-315331	FM ANTENNA SOCKET (U,J,C,A)
14-20x	TA-711186	PRESET INDICATION FILM (EXCEPT J)
14-21x	TA-710902	PRESET INDICATION FILM (J)

MC-Service

INDEX

PARTS NO.	REF. NO.	PARTS NO.	REF. NO.	PARTS NO.	REF. NO.	PARTS NO.	REF. NO.	PARTS NO.	REF. NO.
BA-710967	1-1U	ED-710975	1-D108	ER-336919	1-R40	ET-322778	6-Q208	SP-710950	14-16
BA-710968	1-1J	ED-710978	2-D409	ER-336919	6-R271	ET-322778	6-Q211	SP-710951	13-2U
BA-710969	1-1E	ED-710979	2-D411	ER-337754	7-R209U	ET-327714	11-Q1	SP-710952	13-2J
BA-710977	2-1	ED-710986	6-D202	ER-337754	7-R309U	ET-328265	1-Q101	SP-710953	13-2C
BA-710980	3-1	ED-710988	6-D203	ER-707231	1-T3	ET-328265	1-Q106	SP-710955	13-2A
BA-710981	6-1U	ED-710997	11-D6	ER-710900	11-R2	ET-338410	6-Q307	SP-710956	13-2E
BA-710982	6-1J	ED-710999	11-D5	ER-710900	11-R1	ET-338410	6-Q207	SP-710957	13-2S
BA-710983	6-1E	ED-711092	1-D106	ER-710901	11-R5U	ET-711091	1-Q116	SZ-345569	14-3x
		ED-711092	1-D105	ER-710911	11-R5E	ET-711091	1-Q107	SZ-711005	14-4
BA-710990	7-1U	ED-711138	4-D424	ER-711076	1-SVR4	ET-711091	2-Q439	SZ-711052	13-3
				ER-711076	1-SVR1	ET-711091	2-Q448	TA-710902	14-21x
BA-710991	7-1J	ED-711138	4-D418	ER-711076	1-SVR3	ET-711091	2-Q421	TA-711186	14-20x
BA-710992	7-1C	ED-711138	4-D421	ER-711117	2-RA404	ET-711091	2-Q434		
BA-710993	7-1E	ED-711138	4-Q416	ER-711117	2-RA405	ET-711091	2-Q433		
BD-710919	14-2	ED-711138	4-D417	ER-711118	2-RA403	ET-711091	2-Q423		
BD-710920	14-1	ED-711138	4-D419	ER-711118	3-RA401	ET-711091	2-Q432		
BT-710958	13-1U	ED-711138	4-D423	ER-711119	2-RA406	ET-711091	2-Q424		
BT-710959	13-1U	ED-711138	4-D422	ER-711120	2-RA407	ET-711091	2-Q449		
BT-710960	13-1C	ED-711138	4-D420	ER-711129	3-RA402	ET-711091	2-Q447		
BT-710961	13-1A	ED-711138	4-Q415	ER-711159	7-R208	ET-711091	3-Q405		
BT-710962	13-1E	ED-711161	7-D7						
BT-710963	13-1S	EE-315329	14-17x	ER-711159	7-R308	ET-711091	3-Q407		
EC-314715	6-C330	EE-320526	14-18x	ER-711169	7-R209E	ET-711091	3-Q406		
EC-314715	6-C230	EE-707211	13-4	ER-711169	7-R309E	ET-711091	3-Q404		
EC-314996	1-C85	EE-710970	1-2J	ER-711183	11-R7	ET-711091	3-Q411		
EC-320548	13-C1J	EE-711072	1-2U	ES-336780	4-S6	ET-711091	3-Q410		
EC-330309	6-C239	EF-424811	7-F301J	ES-336780	4-S18	ET-711091	3-Q409		
EC-338411	13-C1U	EF-424811	7-F201J	ES-336780	4-S10	ET-711091	3-Q408		
EC-344157	1-C127	EF-424811	11-F1C	ES-336780	4-S14	ET-711091	4-Q450		
EC-344157	3-C403	EF-623103	11-F1E	ES-336780	4-S15	ET-711091	4-Q451		
EC-710973	1-CT2	EF-623125	7-F301U	ES-336780	4-S9	ET-711091	6-Q214		
EC-711085	1-CA1	EF-623125	7-F201U	ES-336780	4-S7	ET-711091	6-Q216		
EC-711086	1-CA2	EF-668474	13-F2	ES-336780	4-S8	ET-711094	1-Q110		
EC-711130	3-CA401	EH-710971	1-CF3U	ES-336780	4-S17	ET-711116	1-Q117		
EC-711170	7-C16	EH-710971	1-CF1U	ES-336780	4-S19	ET-711116	2-Q429		
EC-711170	7-C17	EH-710971	1-CF2U	ES-336780	4-S12	ET-711116	2-Q444		
ED-327057	1-D119	EH-710972	1-CF1S	ES-336780	4-S16	ET-711116	2-Q438		
ED-327057	1-D109	EH-710972	1-CF3S	ES-336780	4-S11	ET-711116	2-Q443		
ED-327057	1-D116	EH-710972	1-CF2S	ES-336780	4-S13	ET-711116	2-Q431		
ED-327057	1-D118	EH-711084	1-CF4	ES-336780	5-S24	ET-711116	2-Q437		
		EI-202218	1-IC102	ES-336780	5-S23	ET-711116	2-Q441		
ED-327057	1-D112	EI-306728	1-IC104	ES-336780	5-S21	ET-711116	2-Q430		
ED-327057	1-D113	EI-317653	6-IC204	ES-336780	5-S22	ET-711116	2-Q445		
ED-327057	1-D114	EI-337228	6-IC202	ES-336780	5-S25	ET-711116	2-Q442		
ED-327057	1-D111	EI-337228	6-IC307	ES-336780	5-S20	ET-711116	2-Q436		
ED-327057	1-D115	EI-337228	6-IC207	ES-710966	13-11	ET-711116	2-Q435		
ED-327057	1-D102	EI-337417	1-IC101	ES-711056	13-12	ET-711116	2-Q425		
ED-327057	2-D412	EI-343371	6-IC206	ES-711172	9-1	ET-711116	2-Q426		
ED-327057	2-D413	EI-344436	1-IC105	ES-711173	10-1	ET-711116	3-Q416		
ED-327057	2-D410	EI-344437	2-IC402	ET-246846	1-Q111	ET-711116	3-Q419		
ED-327057	3-D402	EI-344438	1-IC103	ET-246846	1-Q104	ET-711116	3-Q415		
ED-327057	3-D407	EI-707240	6-IC208	ET-246846	1-Q102	ET-711116	3-Q403		
ED-327057	3-D406	EI-711077	1-X1	ET-246846	1-Q112	ET-711116	3-Q417		
ED-327057	3-D404	EI-711089	1-IC105	ET-246846	1-Q109	ET-711116	3-Q413		
ED-327057	3-D405	EI-711127	3-IC401	ET-246846	1-Q108	ET-711116	3-Q414		
ED-327057	3-D403	EI-711128	3-X401	ET-246846	1-Q114	ET-711116	3-Q418		
ED-327057	6-D208	EI-711149	6-IC203	ET-246846	1-Q105	ET-711116	3-Q402		
ED-327057	6-D207	EI-711168	7-IC201	ET-246846	1-Q113	ET-711116	3-Q412		
ED-327057	6-D206	EI-711168	7-IC301	ET-246846	1-Q103	EV-707236	6-VR202		
ED-327057	6-D205	EI-711177	11-IC1	ET-246846	3-Q401	EV-710985	6-VR203		
ED-327057	6-D213	EI-711179	11-IC2	ET-246846	6-Q205	EV-710994	7-VR201		
ED-327057	6-D215	EJ-315331	14-19X	ET-246846	6-Q204	EV-710994	7-VR301		
ED-327057	6-D216	EJ-344423	13-5	ET-246846	6-Q217	EW-201515	13-85		
ED-327057	6-D217	EJ-710964	13-6	ET-246846	6-Q305	EW-306427	13-8J		
ED-327057	6-1E	EJ-711054	13-7	ET-246846	6-Q304	EW-306428	13-8U		
ED-327057	6-D204	EJ-711141	6-2	ET-246846	6-Q210	EW-313882	13-8E		
ED-327057	6-D212	EJ-711171	8-J1	ET-246846	6-Q209	EW-343363	13-8C		
ED-327057	6-D214	EM-711114	2-FLD	ET-307195	7-Q201	EZ-706210	13-9U		
ED-327057	6-D210	EO-707227	6-LP201	ET-307195	7-Q301	EZ-706319	13-9C		
ED-336805	7-D8	EO-707227	6-LP301	ET-310165	7-Q303	SA-711043	13-10		
ED-336805	11-D3	EO-711073	1-T1	ET-310165	7-Q203	SK-344330C	14-7		
ED-336805	11-D4	EO-711074	1-T2	ET-310166	7-Q302	SK-344798	14-5		
ED-336805	11-D2	EO-711080	1-L3	ET-310166	7-Q202	SK-344799	14-6		
ED-336805	11-D1	EO-711081	1-L2	ET-316643	7-Q4	SK-711007	14-8		
ED-562386	1-D107	EO-711082	1-T4	ET-316643	7-Q2	SK-711008	14-9		
ED-710903	1-D110J	EO-711083	1-T5	ET-318604	2-Q420	SK-711009	14-10		
ED-710904	6-D10	EO-711184	12-1	ET-322244	7-Q3	SK-711010	14-11		
ED-710913	1-E110U	ER-303342	7-R210	ET-322778	1-Q115	SK-711012	14-12		
ED-710913	3-D401	ER-303342	7-R310	ET-322778	2-Q427	SK-711013	14-13		
ED-710974	1-D101	ER-324251	1-R49	ET-322778	2-Q446	SK-711014	14-14		
ED-710975	1-D103	ER-324251	1-R106	ET-322778	6-Q213	SK-711015	14-15		

LA1245

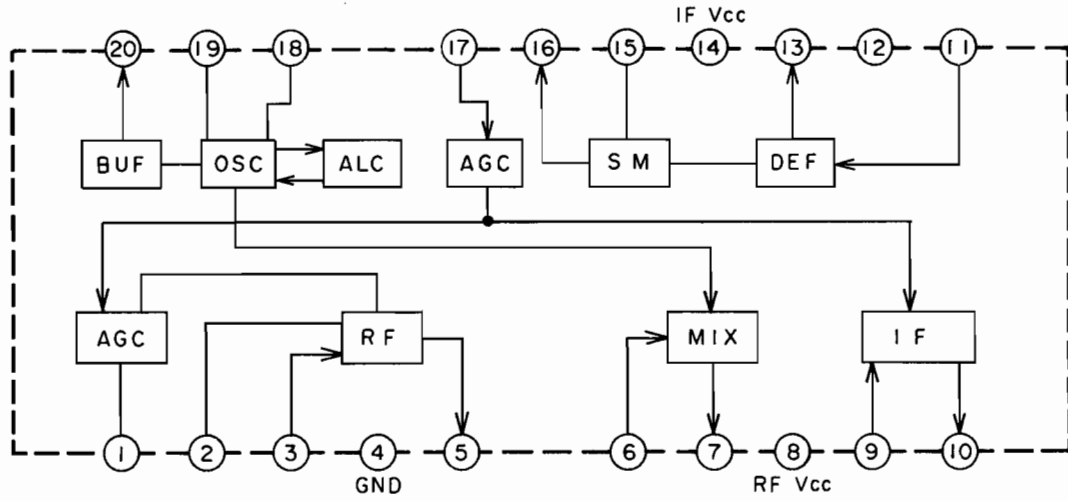

M5218L

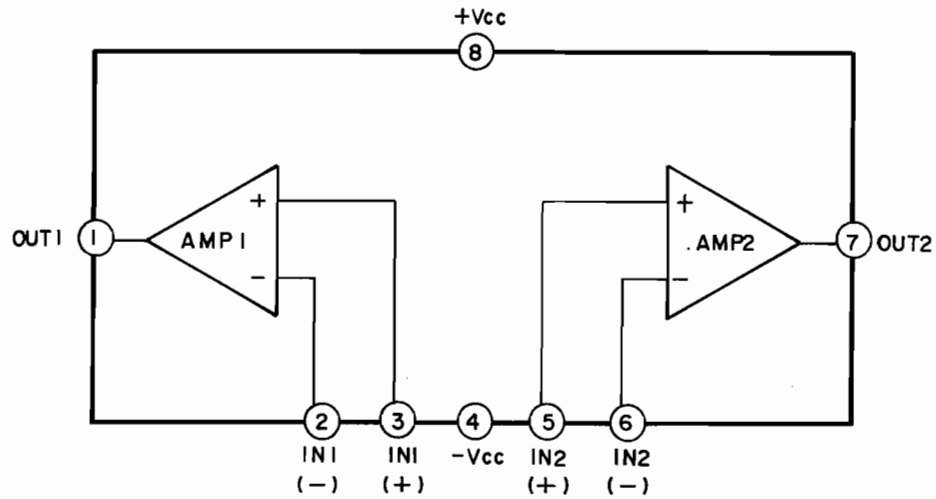

TC4013BP

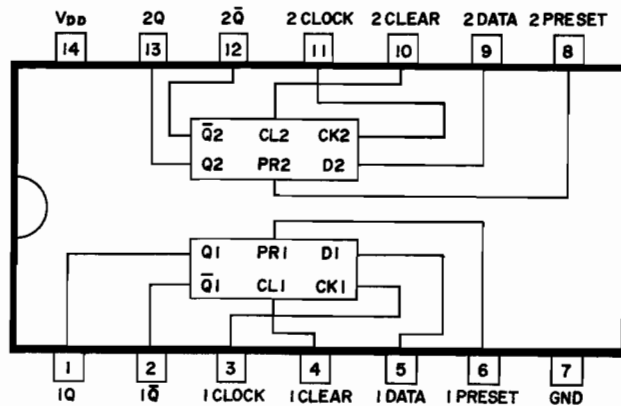

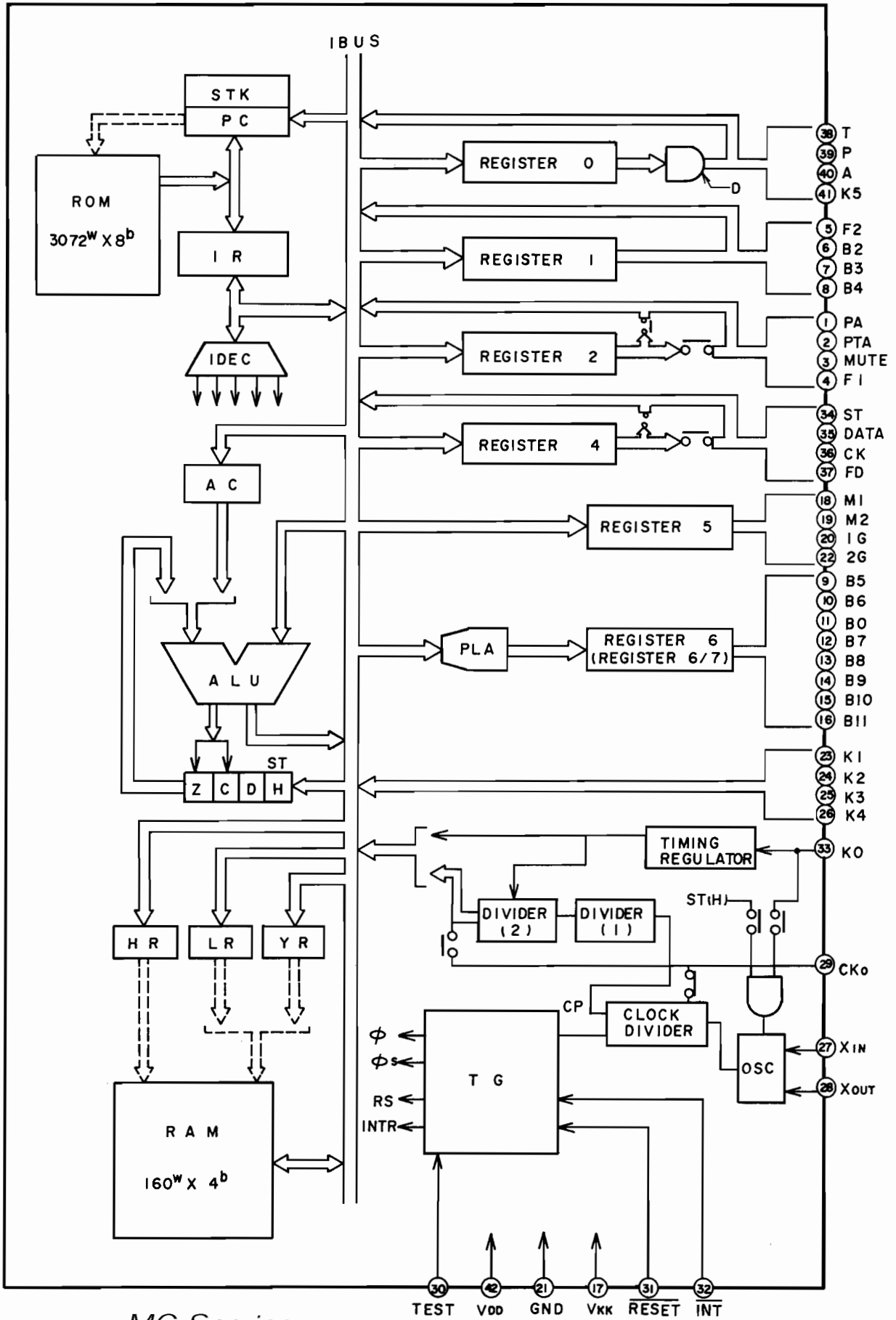

MC-Service

Pin No.	Symbol	Description	
1	PA	Common Segments Display in PHONO, AUX	
2	PTA	Common Segments Display in PHONO, TUNER, AUX	
3	MUTE		
4	F1	Function Switch Control Signal (see Note)	
5	F2		
6	B2	Balance Display Data 	
7	B3		
8	B4		
9	B5		
10	B6		
11	B0		
12	B7		
13	B8		
14	B9		
15	B10		
16	B11		
17	V _{kk}	-16V	
18	M1	Tape Monitor SW Select Signal	
19	M2	Tape Monitor Display Data	
20	1G	DIGIT Signal output	
21	GND		
22	2G	DIGIT Signal output	
23	K1	Phono, Tape Monitor, Vol. (up) Tuner, Vol. (down), Fader AUX, Balance (L) Balance (R)	} Key Input
24	K2		
25	K3		
26	K4		
27	Xin	Clock OSC	
28	Xout		
29	CK0	unused	
30	TEST	unused (To GND)	
31	$\overline{\text{RESET}}$	To +5V	
32	$\overline{\text{INT}}$		
33	K0		
34	STROB	Output Control Signal for Elec. Volume.	
35	DATA		
36	Clock		
37	FD	Segments Display for Fader	
38	T	Segments use in TUNER only	
39	P	Segments use in PHONO only	
40	A	Segments use in AUX only	
41	K5	Tape Monitor, Fader	
42	VDD	+5V	

NOTE: Pin No. 4 and 5 controls Input Mode Selector Switching IC203 ($\mu\text{PD4052BC}$).

		IC203 Function					
Pin No.	Symbol	Pin No.	Symbol	Mode	PHONO	TUNER	AUX
4	F1	9	B		L	L	H
5	F2	10	A		L	H	L

(L = -16V, H = 0V)

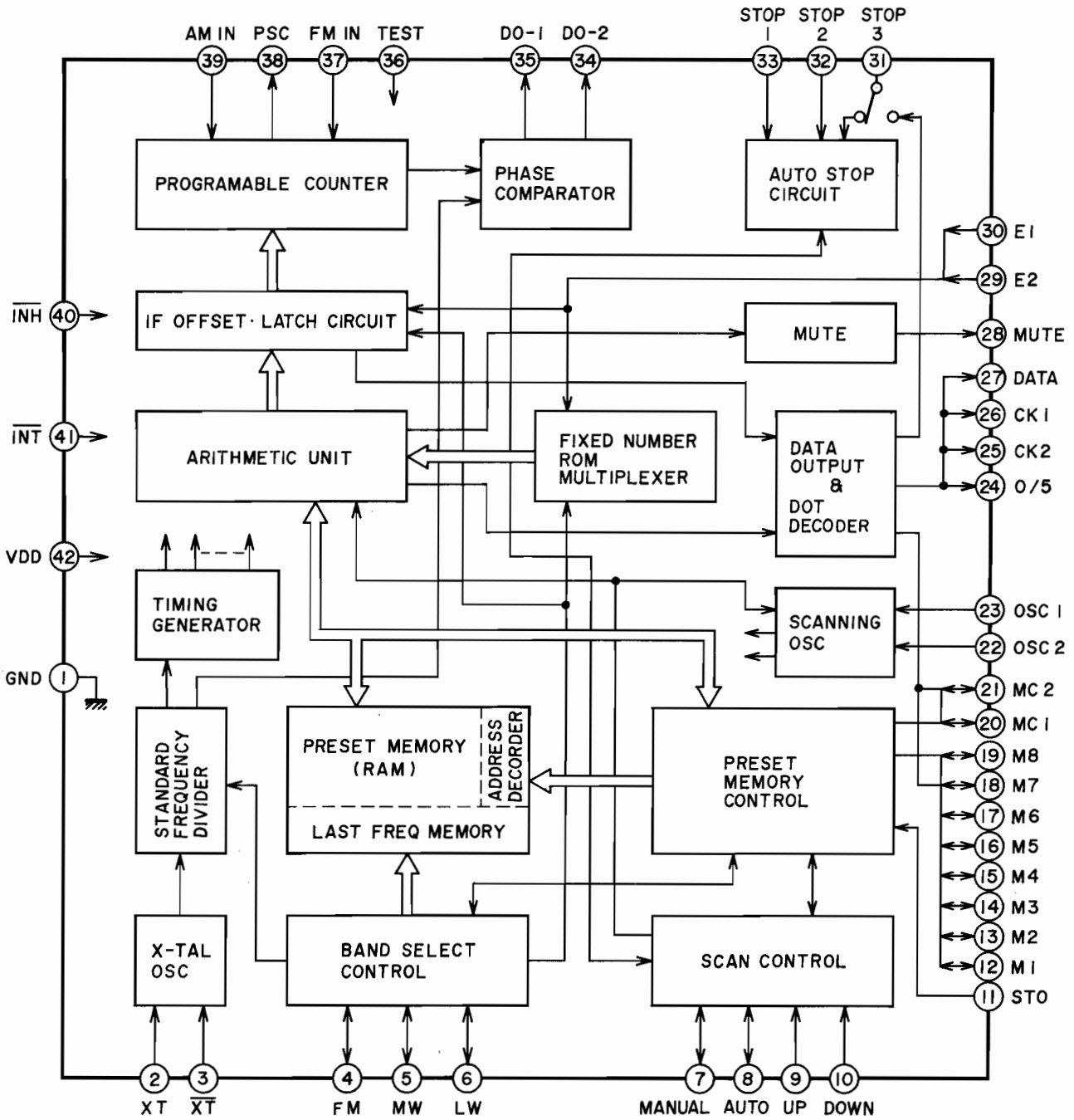

MC-Service

Pin No.	Symbol	Meaning	Function
1	GND	Ground	
2	XT	X-TAL OSC Terminals	Input Terminal of Standard Frequency OSC (X-TAL: 7.2MHz)
3	XT		
4	FM	FM Band Designation Input	Band Selector ACTIVE "High"
5	MW	MW Band Designation Input	
6	LW	LW Band Designation Input	
7	Manual	Manual Tuning Mode	Manual/Auto Tuning Selector
8	Auto	Auto Tuning Mode	
9	UP	UP Operation Key Input	UP/DOWN Tuning Selector
10	Down	Down Operation Key Input	
11	STO	Memory Store Command Input	Memory at preset memory operation
12 } 19	M1 } M8	Preset Memory Channel Designation Inputs	Random Access for 16-Preset-Memory with the inputs of MC1/MC2
20	MC1	Memory Control Input	⑧ Stations (FM/AM)/ ⑩ Stations (FM + MW + LW) Preset Memory Selector
21	MC2		
22	OSC2	AM OSC Terminal	CR Connector Terminal for AM Search Scan Speed
23	OSC1	FM OSC Terminal	CR Connection Terminal for FM Search Scan Speed
24	0/5	FM 50kHz Output	Level "H" Output for 50kHz Step (S. Africa and Europe area)
25	CK2	Receiving Frequency Data Serial Output	Supply Serial Data & Timing Clock to TD6301AP (Receiving Frequency Digital Display Driver)
26	CK1		
27	Data		
28	Mute	Muting Signal Output	Level "H" Output when Muting
29	E2	Area Designation Input	Area Selector (Japan, US, Europe, S. Africa)
30	E1		
31	Stop 3	AM IF Signal Input	Stops Auto Search at AM IF (450kHz)
32	Stop 2	Auto Search Stop Signal Input	Stops Auto Search at Level "H" while Level "H" at Stop 1
33	Stop 1	Scan Speed Slow-Down Input	1/2 Speed-Down of Auto Search at Level "H"
34	DO-2	Phase Comparator Output	Phase Comparator Output
35	DO-1		
36	Test	Test Terminal	Test Mode at Level "H"
37	FM in	FM Programable Counter Input	Connected to Prescaler (TD6104P) Output
38	PSC	Prescaler Control Output	Count-Down (1/30, 1/32) Designation Output for Prescaler
39	AM in	AM Programable Counter Input	AM Local OSC Signal Input
40	$\overline{\text{INH}}$	Inhibit Input	Normal at Level "H" Inhibit at Level "L"
41	$\overline{\text{INT}}$	Initialize Input	Normal at Level "H" Initialize at Level "L"
42	VDD	Power Terminal	+5V is supplied

TC9154P

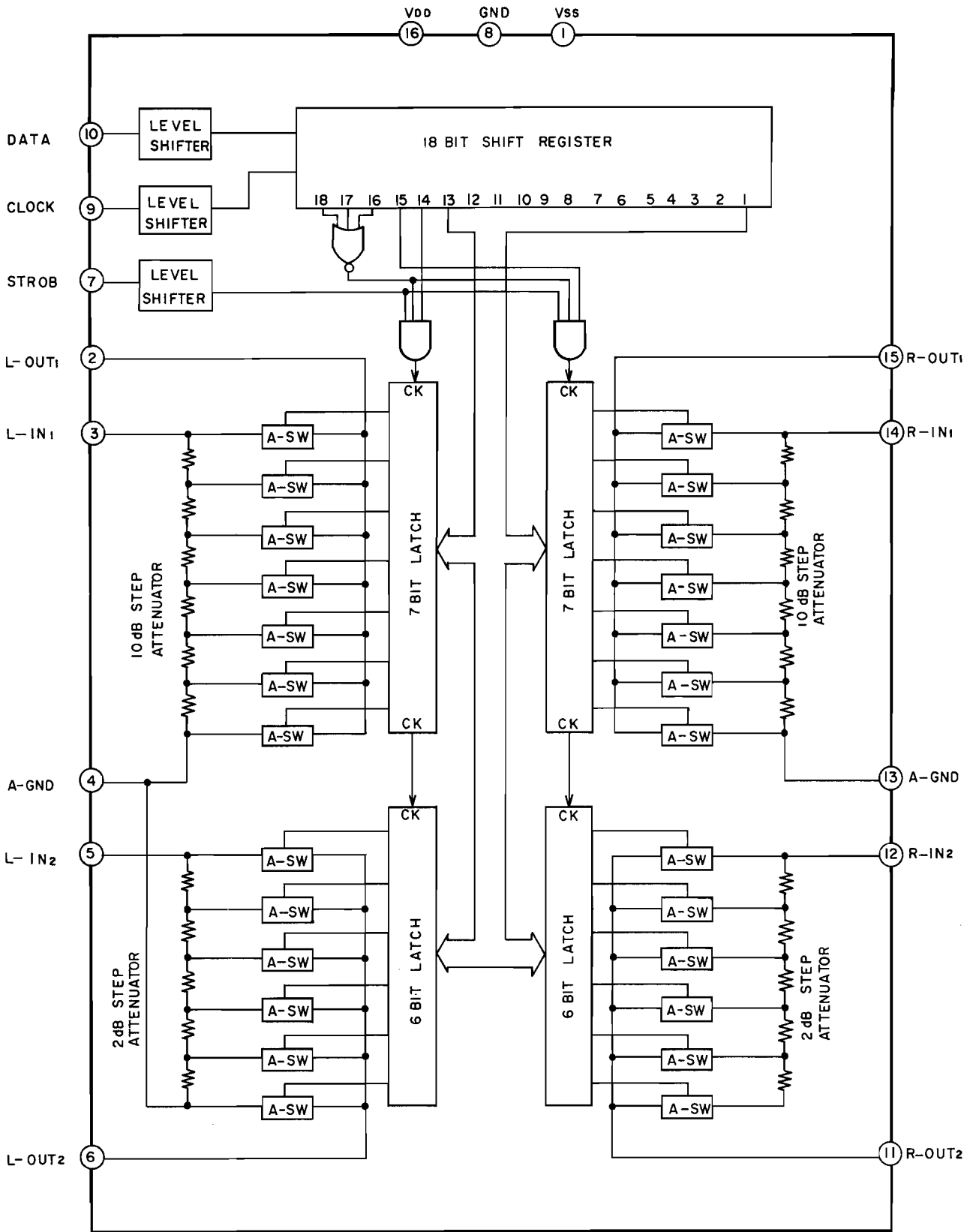

MC-Service

TD6104P

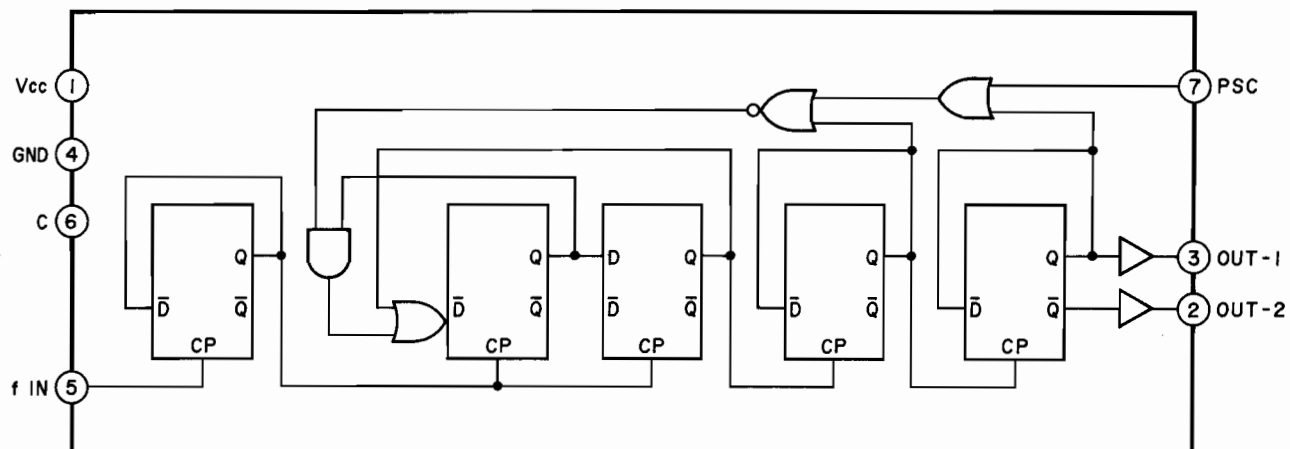

Pin No.	Symbol	Description
5	Fin	FM Local OSC Input
3	OUT-1	Count-Down Frequency Output ($f_{in}/30$ or $f_{in}/32$)
2	OUT-2	Inverted Output of OUT-1
7	PCS	Count-Down-Ratio Switch Signal Input $1/32$ at $V_{psc} \geq 2V$ $1/30$ at $V_{psc} \leq 1V$
6	C	Bypass condenser terminal for bias circuit
1	Vcc	+5V
4	GND	Ground

TD6301AP

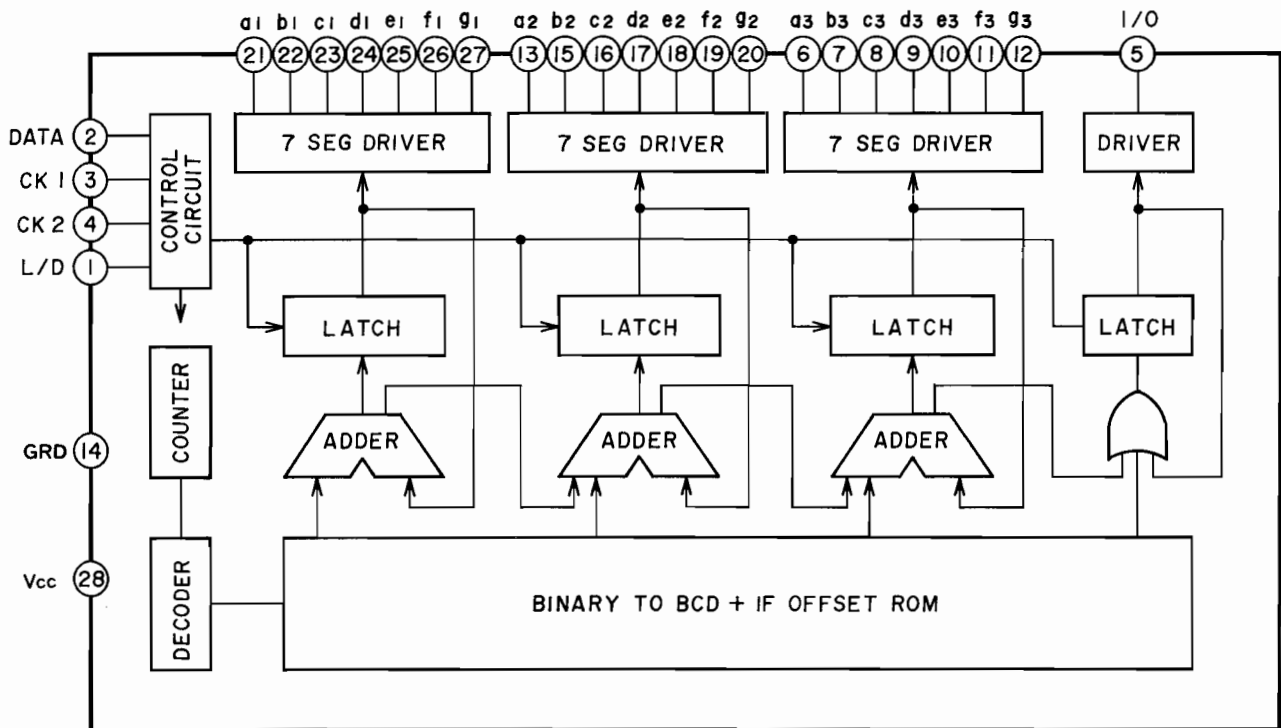

Pin No.	Symbol	Description
1	L/D	Output Select Signal Input Terminal (To Change the Output for various Display such as LED, FL & LCD)
2	Data	Receiving Frequency Data Input Terminal (Serial Input from System Controller LSI)
3	CK1	Control Timing Input Terminal for Receiving Frequency Data Input (Simultaneously W/Data from System Controller LSI)
4	CK2	
5	I/O	Segment Driver Output Terminal for: FM: 100 ^S MHz AM: 1000 ^S kHz
6 ∩ 12	a3 ∩ g3	7 Segment Driver Output Terminals for: FM: 10 ^S MHz AM: 100 ^S kHz
13 ∩ 20	a2 ∩ g2	7 Segment Driver Output Terminals for: FM: 1 ^S MHz AM: 10 ^S kHz
21 ∩ 27	a1 ∩ g1	7 Segment Driver Output Terminals for: FM: 100 ^S kHz AM: 1 ^S kHz
14	Vcc	-16.8V
28	GND	-16.8V

μ PC1161C3

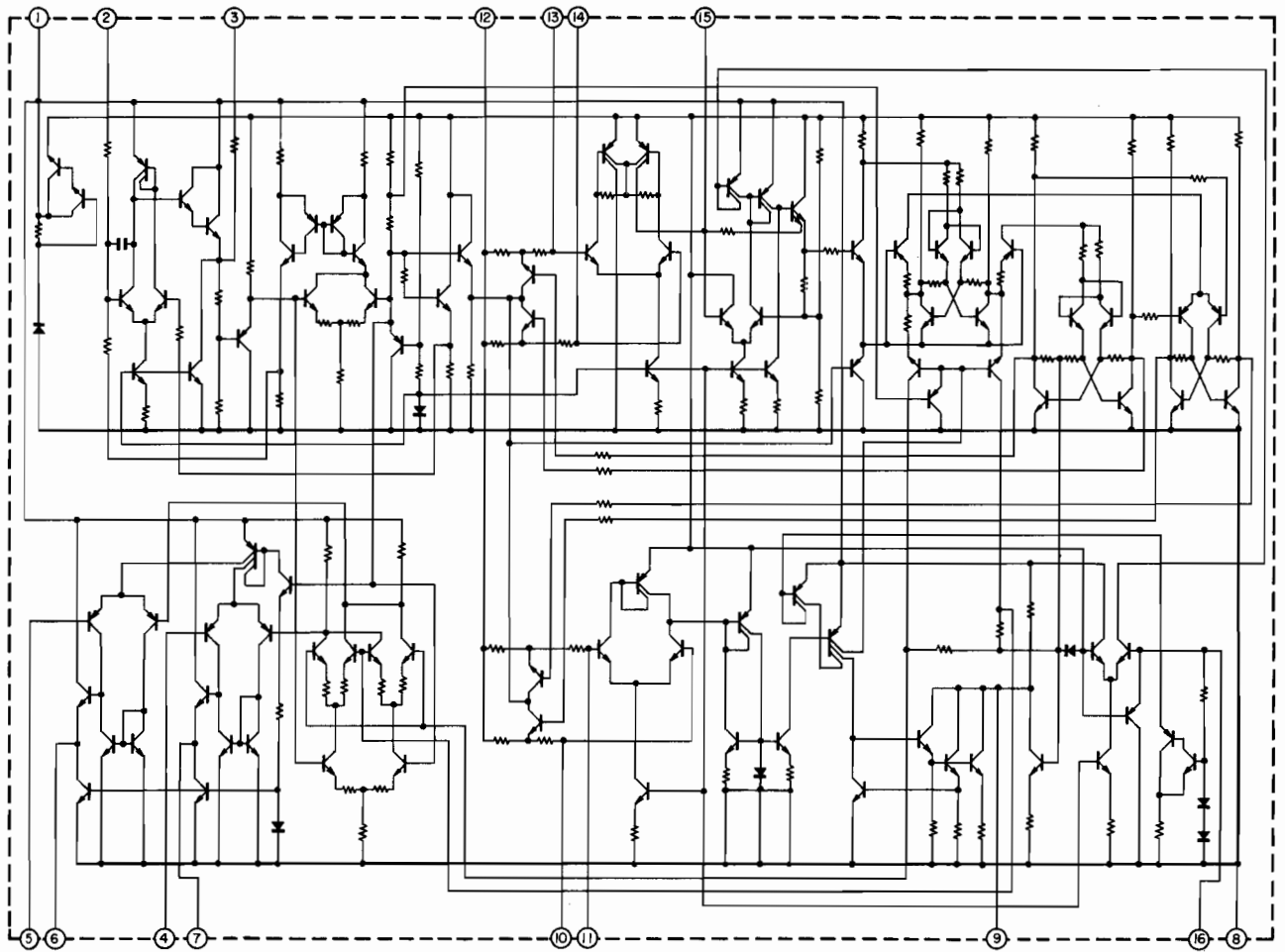

μ PC1270H

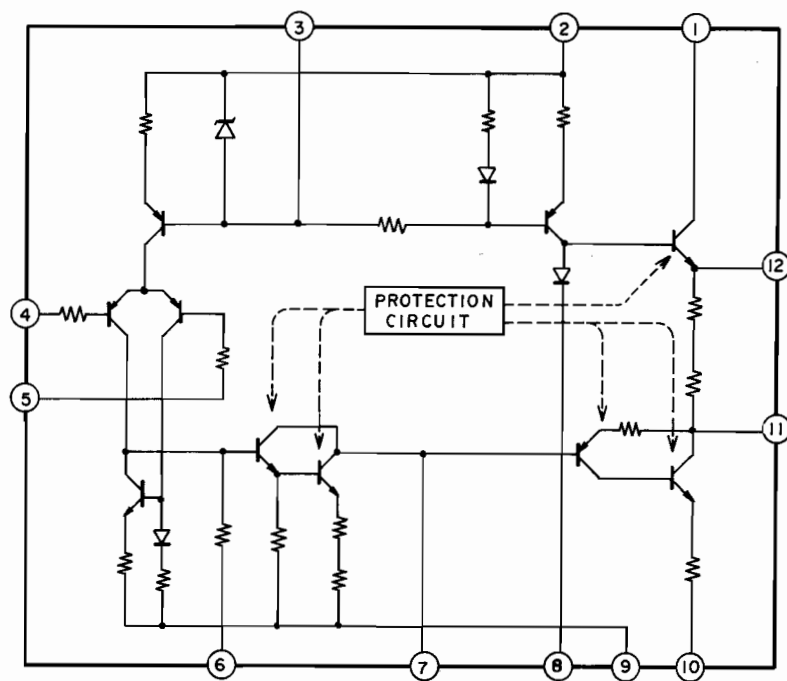

MC-Service

μ PD4052BC

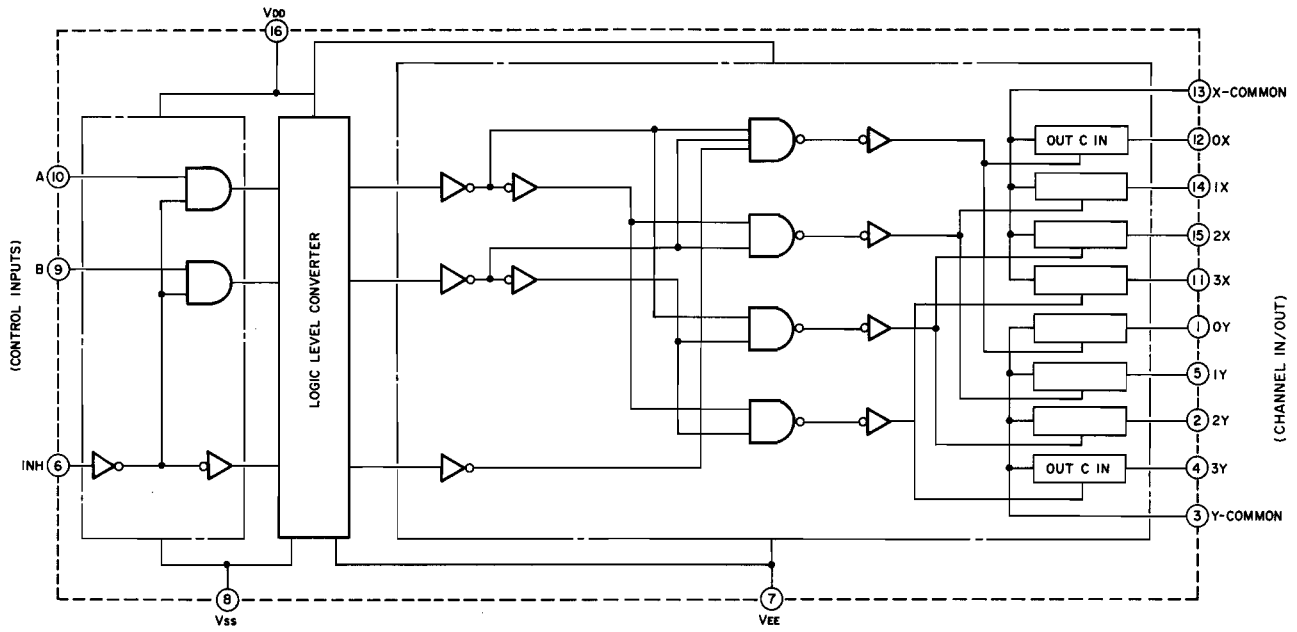

μ PD4066BC

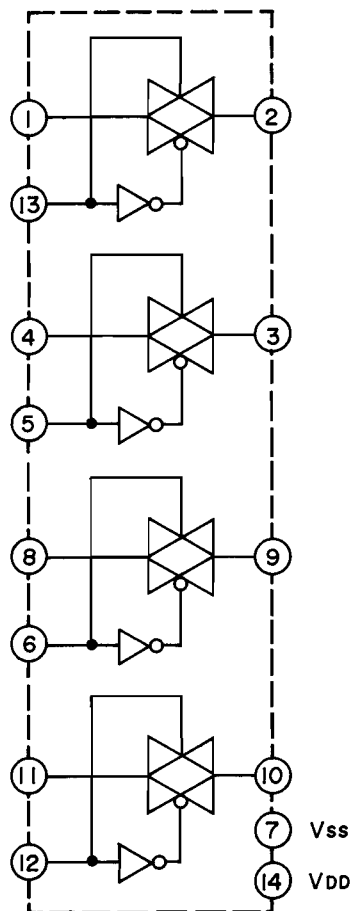

AA-M3

B (POWER SUPPLY) LINE

WARNING: Δ INDICATES SAFETY CRITICAL COMPONENTS FOR CONTINUED SAFETY, REPLACE SAFETY CRITICAL COMPONENTS ONLY WITH MANUFACTURER'S RECOMMENDED PARTS
AVERTISSEMENT: Δ IL INDIQUE LES COMPOSANTS CRITIQUES DE SÉCURITÉ. POUR MAINTENIR LE DEGRÉ DE SÉCURITÉ DE L'APPAREIL, NE REMPLACER QUE DES PIÈCES RECOMMANDÉES PAR LE FABRICANT

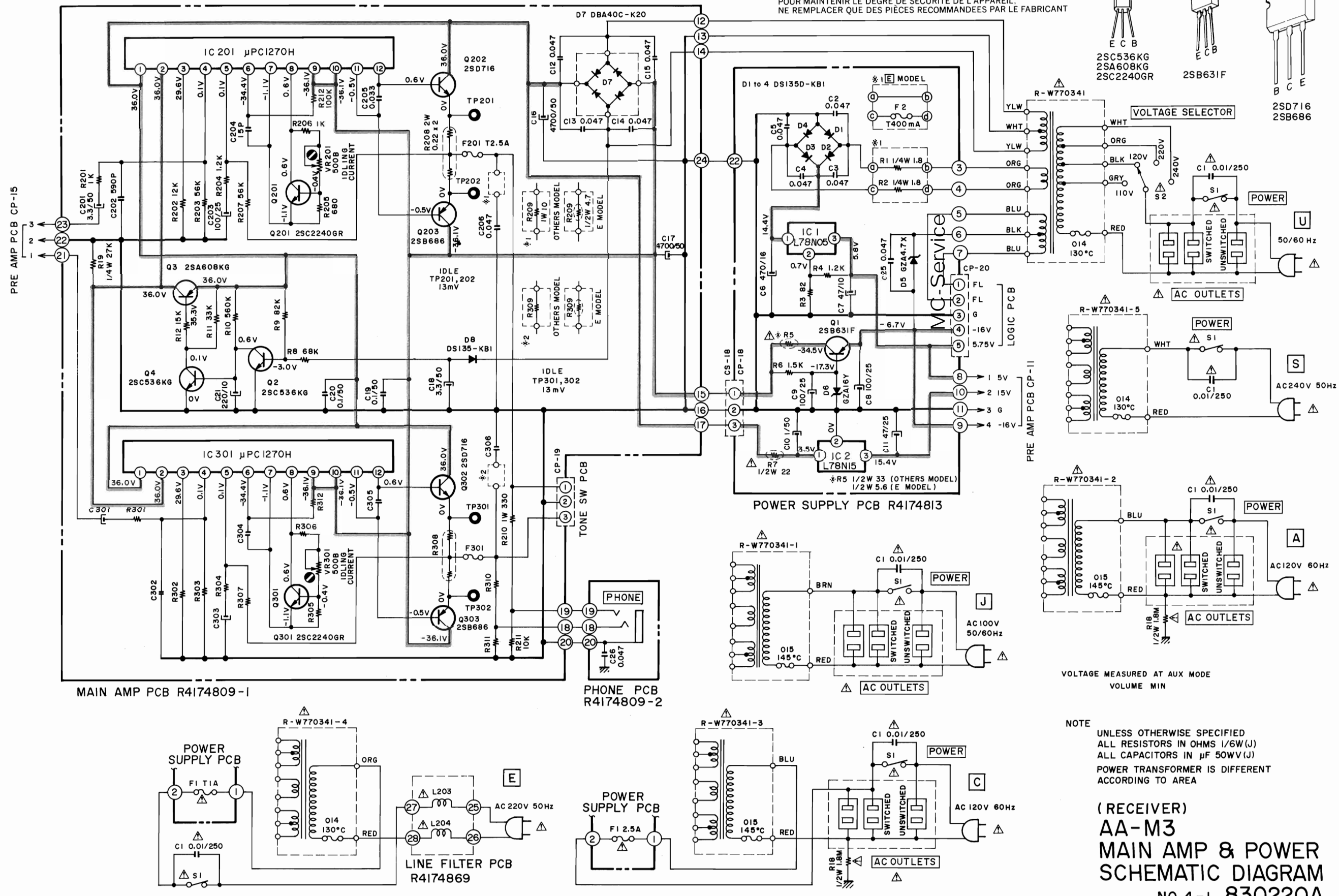
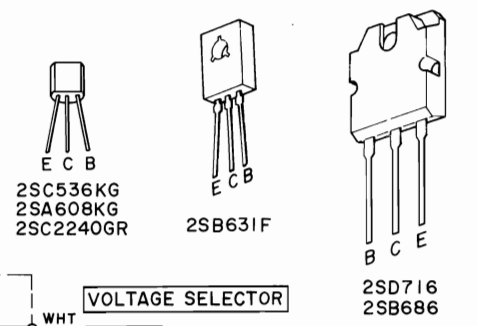

NOTE
UNLESS OTHERWISE SPECIFIED
ALL RESISTORS IN OHMS (1/6W(J))
ALL CAPACITORS IN μF (50WV(J))
POWER TRANSFORMER IS DIFFERENT
ACCORDING TO AREA

(RECEIVER)
AA-M3
MAIN AMP & POWER
SCHEMATIC DIAGRAM
NO. 4-1 830220A

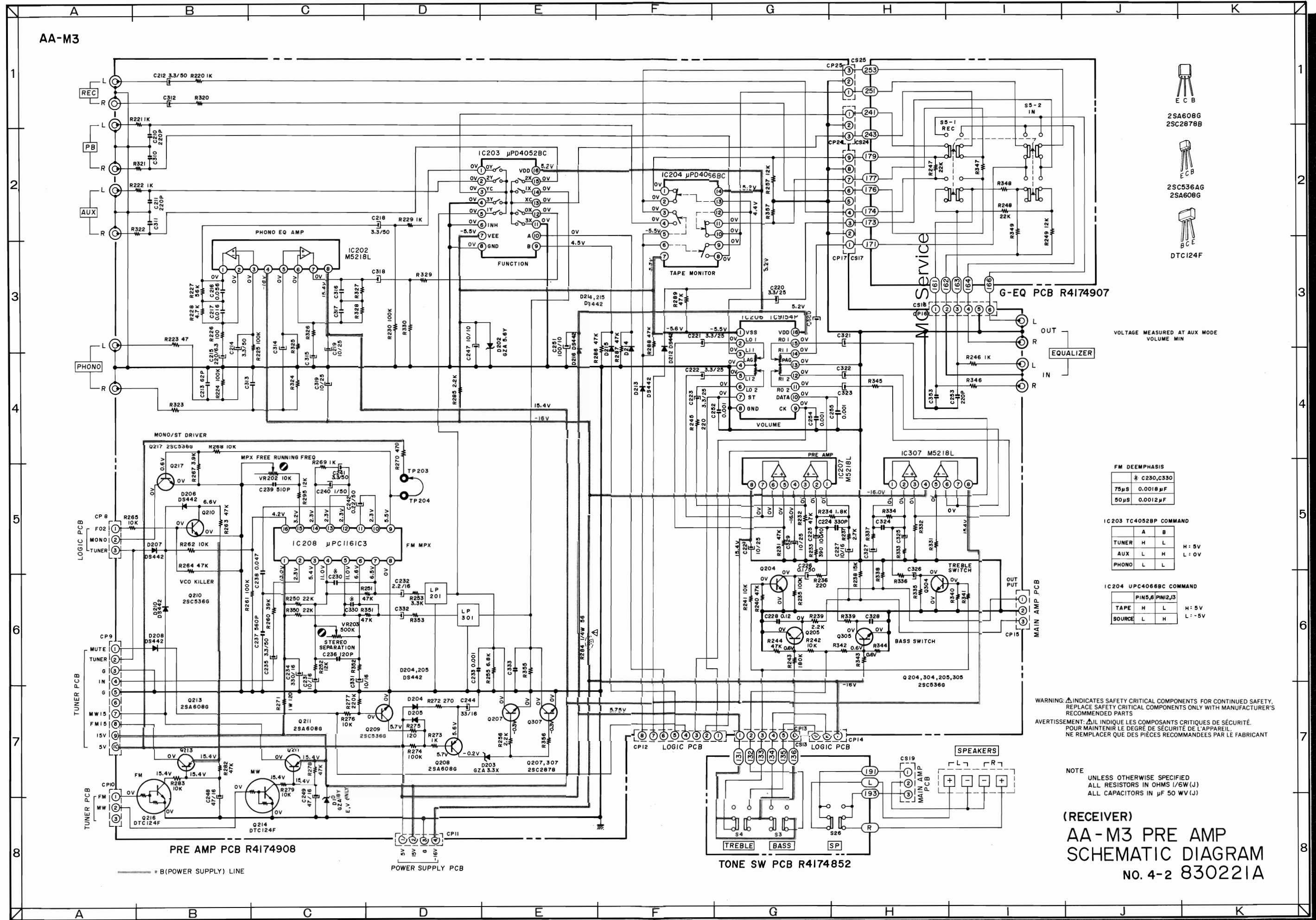

AA-M3

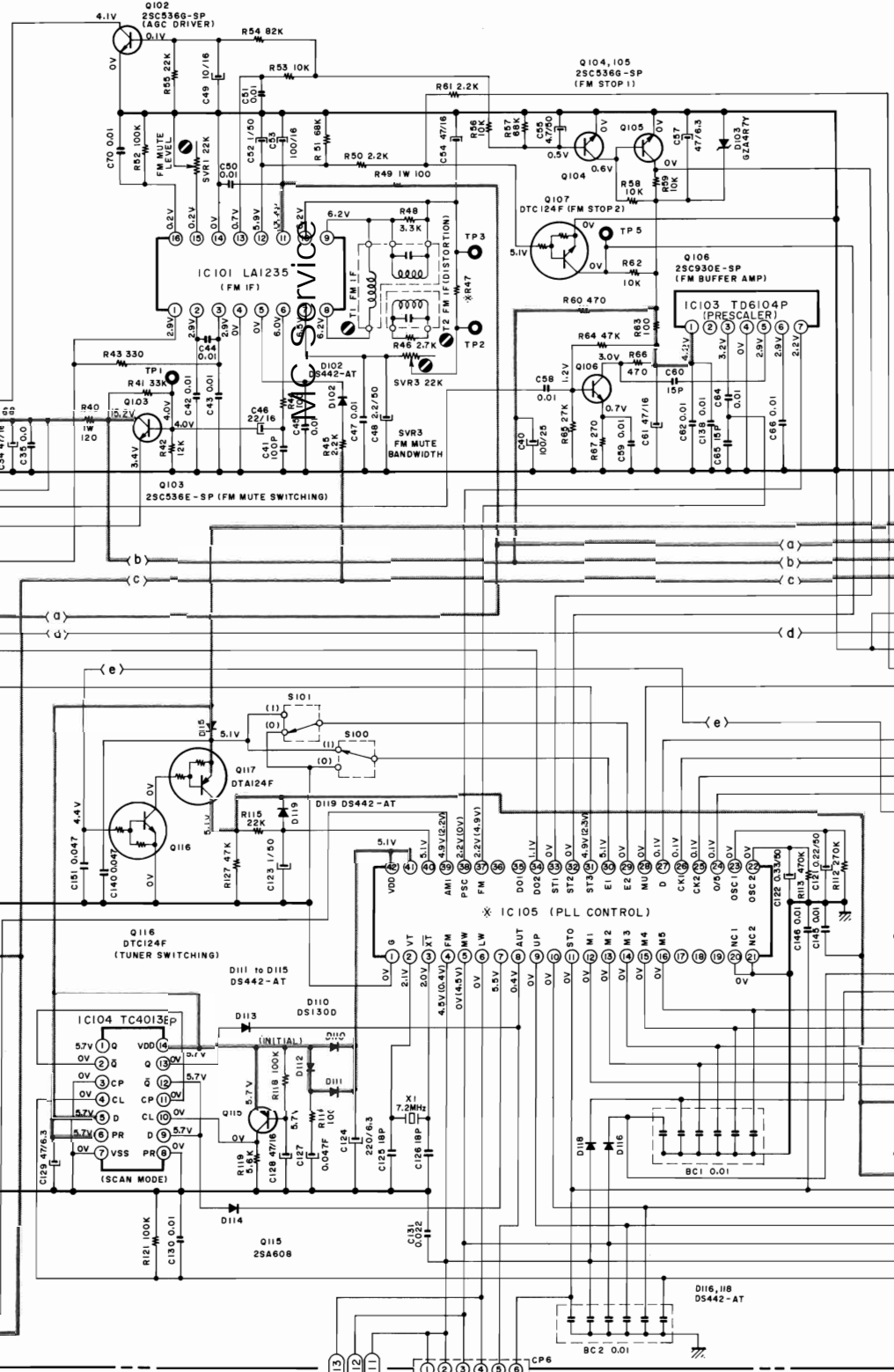
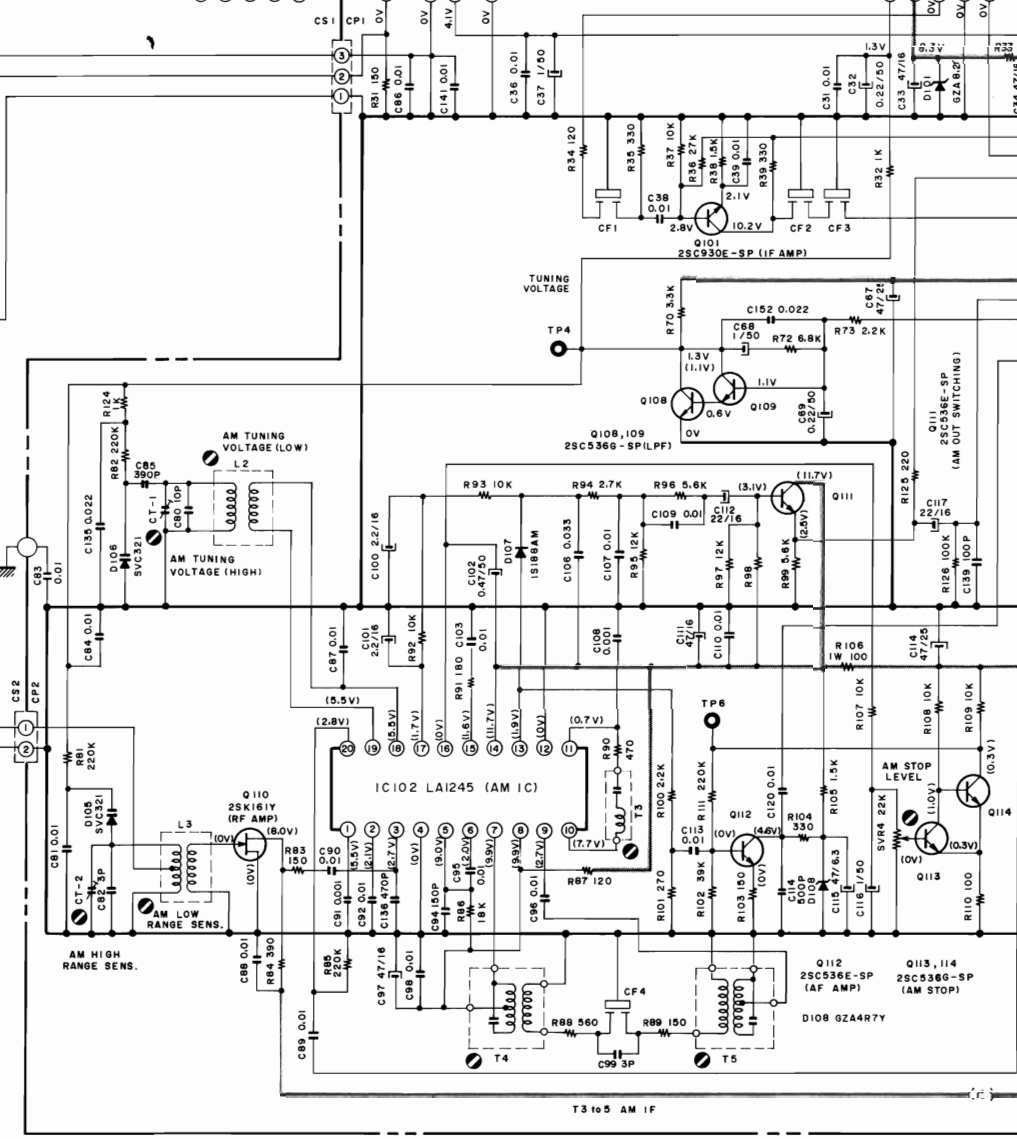
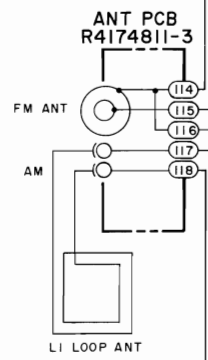
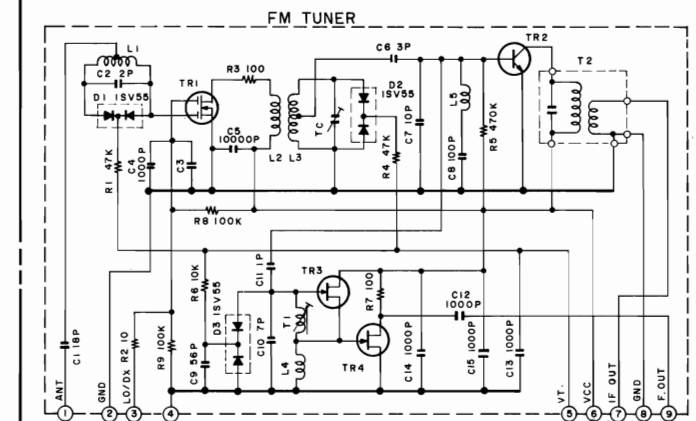
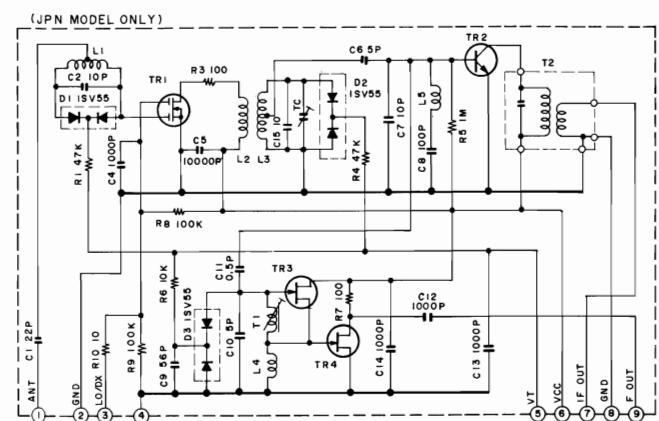

ECB	DGS
2SA608E-NP	2SK161Y
2SC930E-SP	DTC124F
2SC536E-SP	DTA124F
2SC536E-SP	

DIF	*R00	*S101	*IC105	*R47
U1,2,3,5	I	O	TC9157P	10K
UB	I	I	TC9157P	1K
AC	I	I	TC9157P	1K
J	O	O	TC9147P	1K
E	I	O	TC9157P	10K
S	I	O	TC9157P	10K

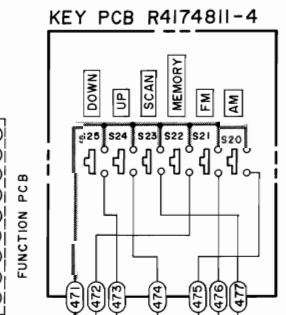

TUNER PCB R4174807

PRE AMP PCB CS10

(RECEIVER)
AA-M3 TUNER
SCHEMATIC DIAGRAM
NO.4-3 830222A

MC-Service

VOLTAGES MEASURED AT FM MODE (87.5 MHz)
VOLTAGES IN () MEASURED AT AM MODE (522 kHz)
FUNCTION TUNER

NOTE
UNLESS OTHERWISE SPECIFIED
ALL RESISTORS IN OHMS (1/6W/J)
ALL CAPACITORS IN μF (50WV/J)

AA-M3

A B C D E F G H I J K

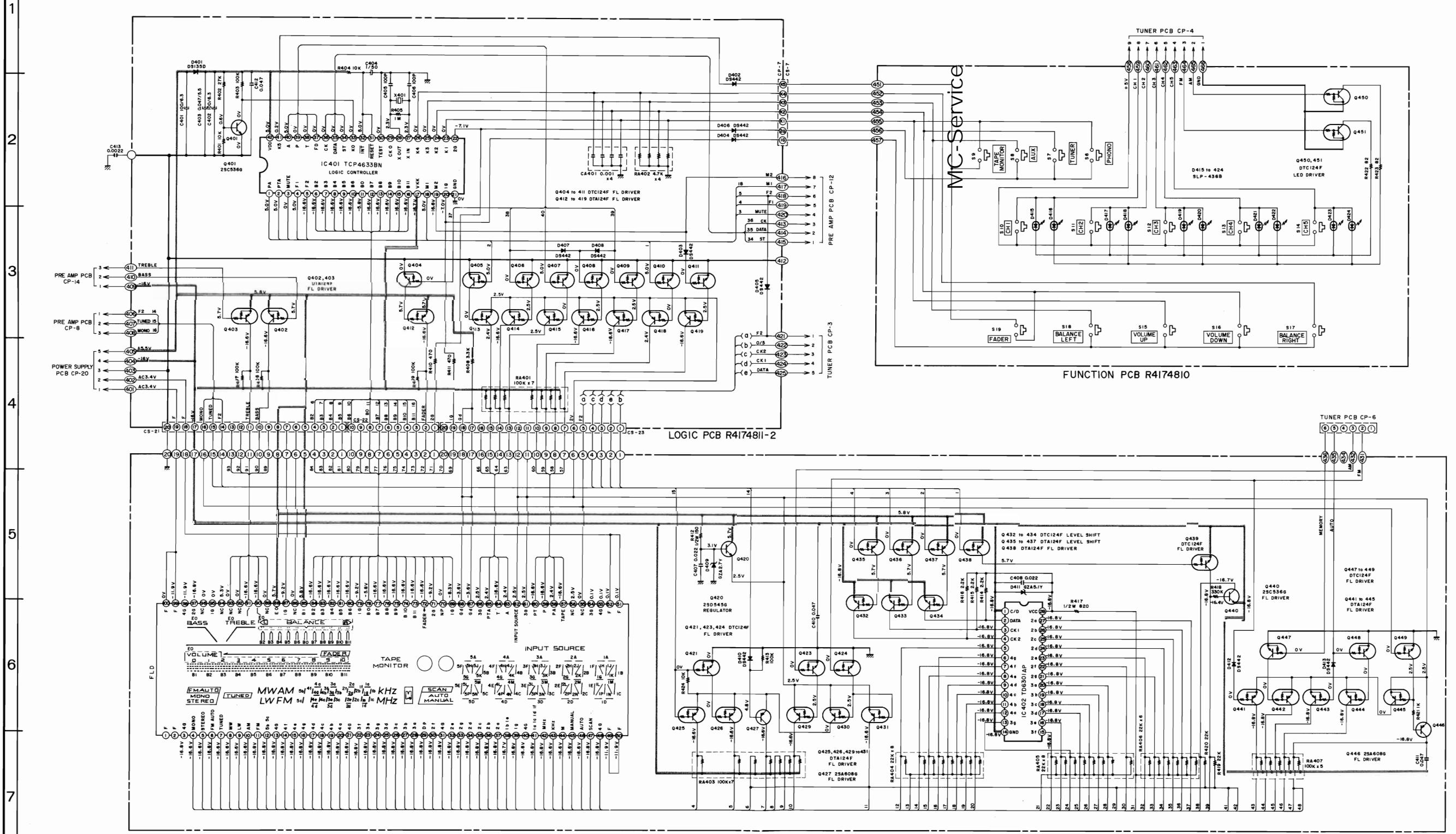

B (POWER SUPPLY) LINE



MC-Service

VOLTAGE MEASURED AT AUX MODE
VOLUME MIN

NOTE
UNLESS OTHERWISE SPECIFIED
ALL RESISTORS IN OHMS (1/W/L)
ALL CAPACITORS IN pF 50WV(1)

(RECEIVER)
AA-M3
DISPLAY & FUNCTION
SCHEMATIC DIAGRAM
No.4-4 830223A